

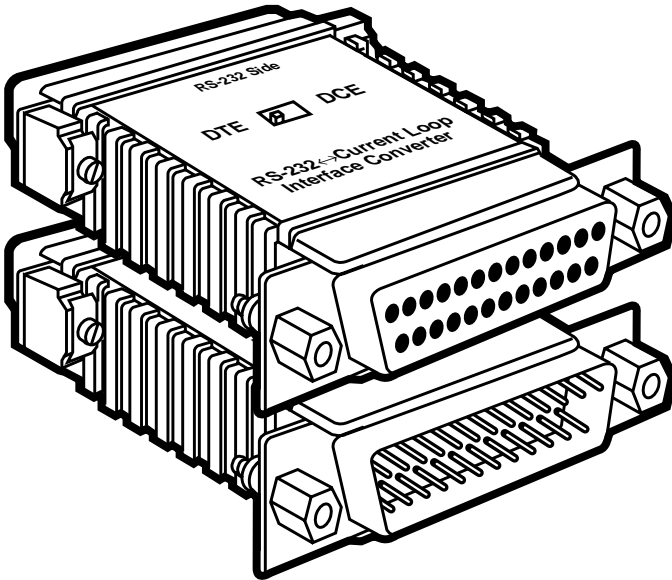

RS-232↔Current Loop Interface Converter



**CUSTOMER
SUPPORT
INFORMATION**

Order toll-free in the U.S. 24 hours, 7 A.M. Monday to midnight Friday: **877-877-BBOX**
FREE technical support, 24 hours a day, 7 days a week: Call **724-746-5500** or fax **724-746-0746**
Mail order: **Black Box Corporation**, 1000 Park Drive, Lawrence, PA 15055-1018
Web site: www.blackbox.com • E-mail: info@blackbox.com

FEDERAL COMMUNICATIONS COMMISSION
AND
INDUSTRY CANADA
RADIO FREQUENCY INTERFERENCE STATEMENTS

This equipment generates, uses, and can radiate radio frequency energy and if not installed and used properly, that is, in strict accordance with the manufacturer's instructions, may cause interference to radio communication. It has been tested and found to comply with the limits for a Class A computing device in accordance with the specifications in Subpart J of Part 15 of FCC rules, which are designed to provide reasonable protection against such interference when the equipment is operated in a commercial environment. Operation of this equipment in a residential area is likely to cause interference, in which case the user at his own expense will be required to take whatever measures may be necessary to correct the interference.

Changes or modifications not expressly approved by the party responsible for compliance could void the user's authority to operate the equipment.

This digital apparatus does not exceed the Class A limits for radio noise emission from digital apparatus set out in the Radio Interference Regulation of Industry Canada.

Le présent appareil numérique n'émet pas de bruits radioélectriques dépassant les limites applicables aux appareils numériques de la classe A prescrites dans le Règlement sur le brouillage radioélectrique publié par Industrie Canada.

**NORMAS OFICIALES MEXICANAS (NOM)
ELECTRICAL SAFETY STATEMENT**

INSTRUCCIONES DE SEGURIDAD

1. Todas las instrucciones de seguridad y operación deberán ser leídas antes de que el aparato eléctrico sea operado.
2. Las instrucciones de seguridad y operación deberán ser guardadas para referencia futura.
3. Todas las advertencias en el aparato eléctrico y en sus instrucciones de operación deben ser respetadas.
4. Todas las instrucciones de operación y uso deben ser seguidas.
5. El aparato eléctrico no deberá ser usado cerca del agua—por ejemplo, cerca de la tina de baño, lavabo, sótano mojado o cerca de una alberca, etc..
6. El aparato eléctrico debe ser usado únicamente con carritos o pedestales que sean recomendados por el fabricante.
7. El aparato eléctrico debe ser montado a la pared o al techo sólo como sea recomendado por el fabricante.
8. Servicio—El usuario no debe intentar dar servicio al equipo eléctrico más allá a lo descrito en las instrucciones de operación. Todo otro servicio deberá ser referido a personal de servicio calificado.
9. El aparato eléctrico debe ser situado de tal manera que su posición no interfiera su uso. La colocación del aparato eléctrico sobre una cama, sofá, alfombra o superficie similar puede bloquea la ventilación, no se debe colocar en libreros o gabinetes que impidan el flujo de aire por los orificios de ventilación.
10. El equipo eléctrico deber ser situado fuera del alcance de fuentes de calor como radiadores, registros de calor, estufas u otros aparatos (incluyendo amplificadores) que producen calor.
11. El aparato eléctrico deberá ser conectado a una fuente de poder sólo del tipo descrito en el instructivo de operación, o como se indique en el aparato.

12. Precaución debe ser tomada de tal manera que la tierra física y la polarización del equipo no sea eliminada.
13. Los cables de la fuente de poder deben ser guiados de tal manera que no sean pisados ni pellizcados por objetos colocados sobre o contra ellos, poniendo particular atención a los contactos y receptáculos donde salen del aparato.
14. El equipo eléctrico debe ser limpiado únicamente de acuerdo a las recomendaciones del fabricante.
15. En caso de existir, una antena externa deberá ser localizada lejos de las líneas de energía.
16. El cable de corriente deberá ser desconectado del cuando el equipo no sea usado por un largo periodo de tiempo.
17. Cuidado debe ser tomado de tal manera que objetos líquidos no sean derramados sobre la cubierta u orificios de ventilación.
18. Servicio por personal calificado deberá ser provisto cuando:
 - A: El cable de poder o el contacto ha sido dañado; u
 - B: Objetos han caído o líquido ha sido derramado dentro del aparato; o
 - C: El aparato ha sido expuesto a la lluvia; o
 - D: El aparato parece no operar normalmente o muestra un cambio en su desempeño; o
 - E: El aparato ha sido tirado o su cubierta ha sido dañada.

TRADEMARKS USED IN THIS MANUAL

Any trademarks mentioned in this manual are acknowledged to be the property of the trademark owners.

Contents

1. Specifications	6
2. Introduction	7
2.1 Description	7
2.2 Features	7
3. Configuration and Installation	8
3.1 Setting the DCE/DTE Switch	8
3.2 Installing the Converter	8
3.2.1 RS-232 to Active Current Loop Running Passive	8
3.2.2 RS-232 to Passive Current Loop Running Active	9
4. Troubleshooting	11
4.1 Calling Black Box	11
4.2 Shipping and Packaging	11
Appendix A: Block Diagram	12
Appendix B: Pinouts	13
B.1 The Converter's RS-232 Interface	13
B.2 The Converter's Current-Loop Interface	14

1. Specifications

Isolation—2500 V RMS via opto-isolators on line side

Maximum Distance—Up to 4 miles (6.4 km) on 24 AWG twisted pair

Operation—Asynchronous, full-duplex

Speed—Up to 115.2 kbps

Transmission Mode—Full- or half-duplex

Transmission Line—19 to 26 AWG twisted pair

Interface—RS-232, V.24 (0.5 mm), 20-mA Current Loop

Temperature Tolerance—32 to 140°F (0 to 60°C)

Altitude—Up to 15,000 ft. (4572 m)

Humidity—5 to 95% noncondensing

Connectors—CL060A-F: RS-232: (1) DB25 female; Current Loop: (1) DB25 male; CL060A-M: RS-232: (1) DB25 male; Current Loop: (1) DB25 female

Power—For passive operation: No external power, uses power from data and control signals

Size—0.8"H x 2.1"W x 2.2"D (2 x 5.3 x 5.6 cm)

Weight—1.7 oz. (48.2 g)

2. Introduction

2.1 Description

The RS-232↔Current Loop Interface Converter lets an asynchronous RS-232 device communicate with a 20-mA current-loop device. The Converter requires no AC power or batteries to operate as a passive device and supports data rates of up to 115.2 kbps. When connected to an active current-loop interface, no additional power is needed. When connected to a passive current-loop interface, DC line power may be applied to the Converter via pins 9 and 21 of the DB25 current-loop interface.

Operating in full-duplex mode, the Converter supports communication distances of up to 4 miles (6.4 km) over two unconditioned twisted pair. To guard against data loss caused by ground loops, the Converter is equipped with 2500 V RMS optical isolators on the line side.

The Converter connects directly to either the RS-232 interface or the 20-mA current-loop interface using a male or female DB25 connector. An external RS-232 DCE/DTE switch on the Converter eliminates the need for a crossover cable on the RS-232 interface.

2.2 Features

- Full-duplex, asynchronous transmission over 4 wires.
- Operates actively or passively.
- Supports data rates of up to 115.2 kbps.
- Maximum distance of up to 4 miles (6.4 km) on 24 AWG twisted pair.
- No AC power required.
- Optically isolated on the line side.
- DB25 connectors on both ends.
- External RS-232 DCE/DTE switch.

3. Configuration and Installation

The RS-232↔Current Loop Interface Converter is easy to use. It contains no internal jumpers or DIP switches to set, so you'll never have to open the case to configure the unit. The only configuration required for operation is proper setting of the external RS-232 DCE/DTE switch.

3.1 Setting the DCE/DTE Switch

For your convenience, the Converter has an externally accessible DCE/DTE switch (see Figure 3-1). If the RS-232 device connected to the Converter is a modem or multiplexer (or is wired like one), set the switch to "DTE." This setting causes the Converter to behave like Data Terminal Equipment, transmitting data on RS-232 pin 2 and receiving data on pin 3.

If the RS-232 device connected to the Converter is a PC, terminal, or host computer (or is wired like one), set the switch to "DCE." This setting causes the Converter to behave like Data Communications Equipment, transmitting data on RS-232 pin 3 and receiving data on pin 2. Remember, the switch setting is always from the point of view of the Converter, not the connected equipment.

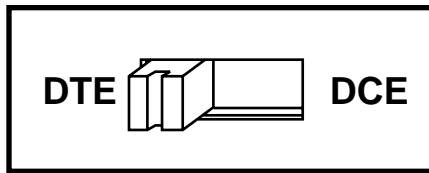

Figure 3-1. DCE/DTE Switch Positions.

3.2 Installing the Converter

You can install the Converter in two different applications: RS-232 to *active* current loop or RS-232 to *passive* current loop.

3.2.1 RS-232 TO ACTIVE CURRENT LOOP RUNNING PASSIVE

The simplest installation of the Converter is into environments where an RS-232 device is communicating with an *active* current-loop device. In this case, both the RS-232 and current-loop interfaces are automatically supplying power to the data circuit. As Figure 3-2 illustrates, only 4 wires are needed to connect the current

loop side of the Converter to the current-loop device interface. For best results, these 4 wires should be in twisted pairs.

To install the Converter in an active current-loop environment, you will need a DB25 cable with at least 4 conductors. These conductors should be wired to the appropriate DB25 pins as shown in Figure 3-2. Since the end of this cable connects to the Converter, its gender should be opposite to that of the Converter's connector. When you connect this cable to your current-loop device, be sure the signal paths correspond to those shown.

The RS-232 side of the Converter is designed to plug directly into the serial port of your RS-232 device. You may use a straight-through RS-232 cable for connection as well. Be sure to set the Converter's DCE/DTE switch according to the instructions in **Section 3.1**.

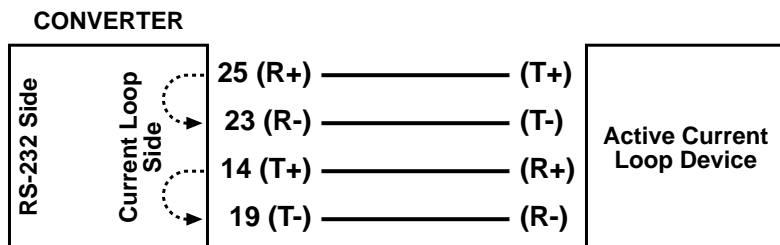

Figure 3-2. Connection to an Active Current-Loop Interface.

3.2.2 RS-232 TO PASSIVE CURRENT LOOP RUNNING ACTIVE

You may install the Converter into environments where an RS-232 device is communicating with a passive current-loop device. In this case, you will need to supply external DC power to the Converter on the current-loop interface side. Figure 3-3 shows the appropriate pins/voltages for applying external DC power to the Converter.

To install the Converter in a passive current-loop environment, you will need a DB25 cable with at least 3 conductors plus shield. Wire the cable as shown in Figure 3-3, paying attention to jumpers and signal paths. Since this end of the cable connects to the Converter, its gender should be *opposite* that of the Converter's connector. When you connect this cable to your current-loop device, be sure the signal paths correspond to those shown.

The RS-232 side of the Converter is designed to plug directly into the serial port of your RS-232 device. You may use a straight-through RS-232 cable for connection

as well. Be sure to set the Converter's DCE/DTE switch according to the instructions in **Section 3.1**.

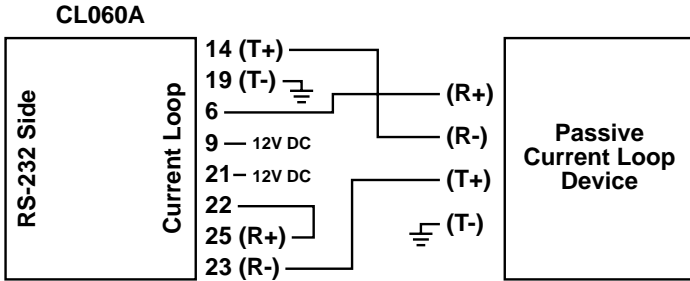

Figure 3-3. Connection to a Passive Current-Loop Device.

4. Troubleshooting

4.1 Calling Black Box

If you determine that your RS-232↔Current Loop Interface Converter is malfunctioning, *do not attempt to alter or repair it*. It contains no user-serviceable parts. Contact Black Box Technical Support at 724-746-5500.

Before you do, make a record of the history of the problem. We will be able to provide more efficient and accurate assistance if you have a complete description, including:

- the nature and duration of the problem;
- when the problem occurs;
- the components involved in the problem;
- any particular application that, when used, appears to create the problem or make it worse; and
- the results of any testing you've already done.

4.2 Shipping and Packaging

If you need to transport or ship your RS-232↔Current Loop Interface Converter:

- Package it carefully. We recommend that you use the original container.
- Before you ship it back to Black Box for repair or return, contact us to get a Return Authorization (RA) number.

Appendix A: Block Diagram

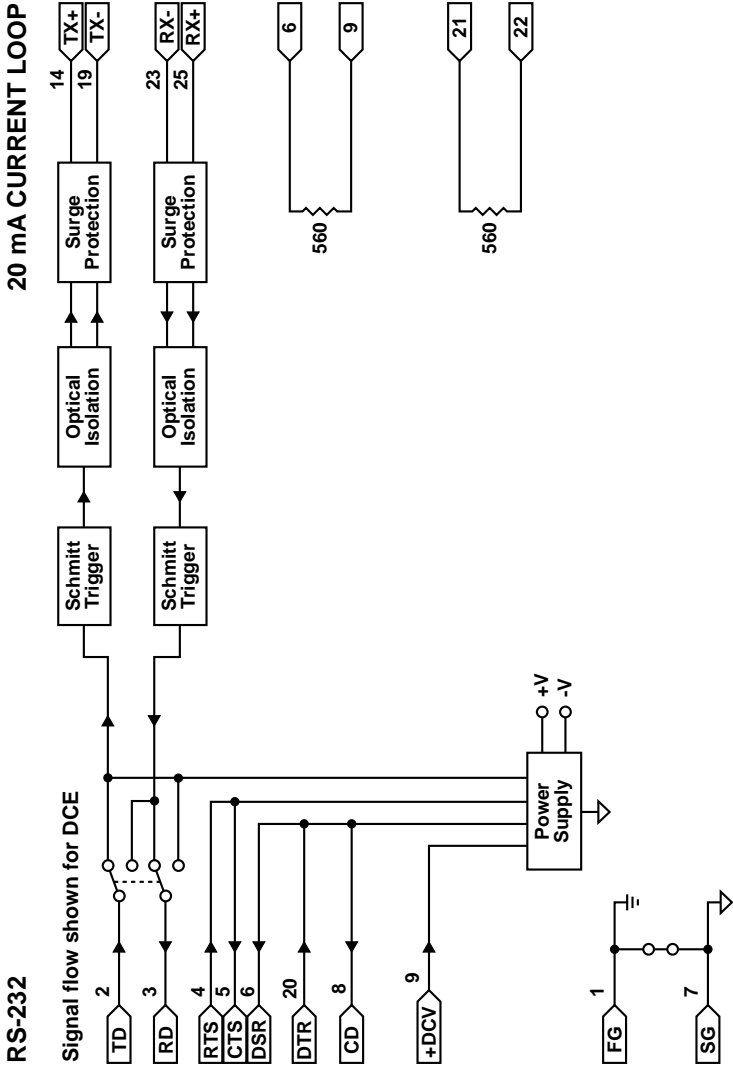

Appendix B: Pinouts

B.1 The Converter's RS-232 Interface

Figure B-1 shows how the RS-232↔Current Loop Interface Converter's RS-232 interface is pinned when it's set as DCE. Figure B-2 that shows how the RS-232 interface is pinned when it's set as DTE. (See **Section 3.1.**)

DIRECTION	"DCE" SETTING	DIRECTION
To CL060A		To CL060A From CL060A To CL060A From CL060A From CL060A From CL060A

Figure B-1. Pinout of the Converter's RS-232 Interface (Set to DCE).

DIRECTION	"DTE" SETTING	DIRECTION
From CL060A		From CL060A To CL060A From CL060A From CL060A To CL060A To CL060A To CL060A

Figure B-2. Pinout of the Converter's RS-232 Interface (Set to DTE).

B.2 The Converter's Current-Loop Interface

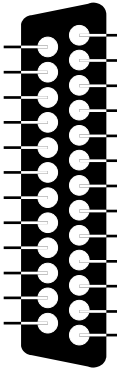
Figure B-3 shows how the RS-232↔Current Loop Interface Converter's current-loop interface is pinned.

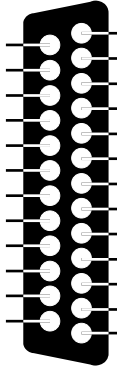
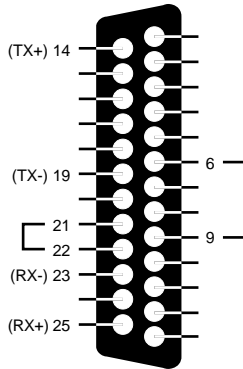

Figure B-3. Pinout of the Converter's Current-Loop Interface.



© Copyright 2001. Black Box Corporation. All rights reserved.

1000 Park Drive • Lawrence, PA 15055-1018 • 724-746-5500 • Fax 724-746-0746