

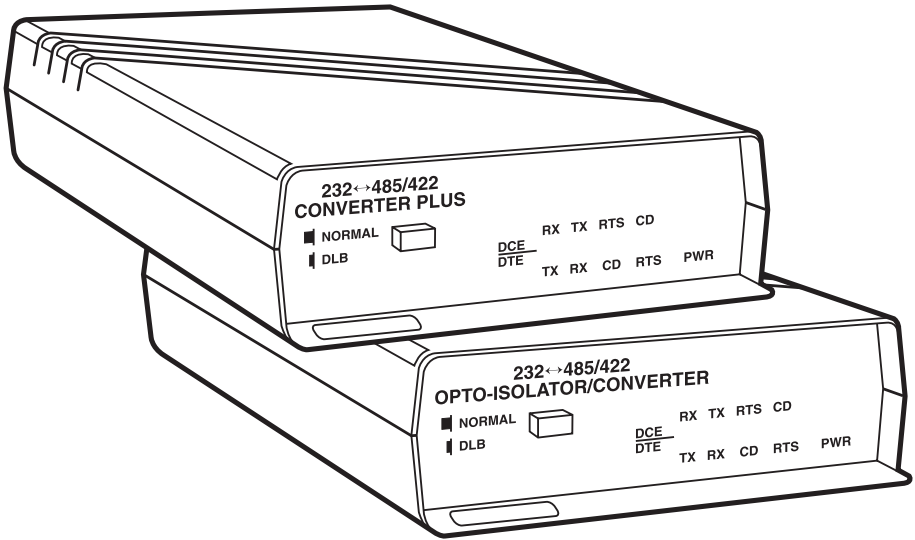

RS-232↔485/422 Converter Plus

RS-232↔485/422 Opto-Isolator/Converter



**CUSTOMER
SUPPORT
INFORMATION**

Order toll-free in the U.S.: Call **877-877-BBOX** (outside U.S. call **724-746-5500**)
 FREE technical support 24 hours a day, 7 days a week: Call **724-746-5500** or fax **724-746-0746**
 Mailing address: **Black Box Corporation**, 1000 Park Drive, Lawrence, PA 15055-1018
 Web site: www.blackbox.com • E-mail: info@blackbox.com

**FEDERAL COMMUNICATIONS COMMISSION
AND
INDUSTRY CANADA
RADIO FREQUENCY INTERFERENCE STATEMENTS**

This equipment generates, uses, and can radiate radio-frequency energy, and if not installed and used properly, that is, in strict accordance with the manufacturer's instructions, may cause interference to radio communication. It has been tested and found to comply with the limits for a Class A computing device in accordance with the specifications in Subpart B of Part 15 of FCC rules, which are designed to provide reasonable protection against such interference when the equipment is operated in a commercial environment. Operation of this equipment in a residential area is likely to cause interference, in which case the user at his own expense will be required to take whatever measures may be necessary to correct the interference.

Changes or modifications not expressly approved by the party responsible for compliance could void the user's authority to operate the equipment.

This digital apparatus does not exceed the Class A limits for radio noise emission from digital apparatus set out in the Radio Interference Regulation of Industry Canada.

Le présent appareil numérique n'émet pas de bruits radioélectriques dépassant les limites applicables aux appareils numériques de la classe A prescrites dans le Règlement sur le brouillage radioélectrique publié par Industrie Canada.

**NORMAS OFICIALES MEXICANAS (NOM)
ELECTRICAL SAFETY STATEMENT****INSTRUCCIONES DE SEGURIDAD**

1. Todas las instrucciones de seguridad y operación deberán ser leídas antes de que el aparato eléctrico sea operado.
2. Las instrucciones de seguridad y operación deberán ser guardadas para referencia futura.
3. Todas las advertencias en el aparato eléctrico y en sus instrucciones de operación deben ser respetadas.
4. Todas las instrucciones de operación y uso deben ser seguidas.
5. El aparato eléctrico no deberá ser usado cerca del agua—por ejemplo, cerca de la tina de baño, lavabo, sótano mojado o cerca de una alberca, etc..
6. El aparato eléctrico debe ser usado únicamente con carritos o pedestales que sean recomendados por el fabricante.
7. El aparato eléctrico debe ser montado a la pared o al techo sólo como sea recomendado por el fabricante.
8. Servicio—El usuario no debe intentar dar servicio al equipo eléctrico más allá a lo descrito en las instrucciones de operación. Todo otro servicio deberá ser referido a personal de servicio calificado.
9. El aparato eléctrico debe ser situado de tal manera que su posición no interfiera su uso. La colocación del aparato eléctrico sobre una cama, sofá, alfombra o superficie similar puede bloquea la ventilación, no se debe colocar en libreros o gabinetes que impidan el flujo de aire por los orificios de ventilación.
10. El equipo eléctrico deber ser situado fuera del alcance de fuentes de calor como radiadores, registros de calor, estufas u otros aparatos (incluyendo amplificadores) que producen calor.
11. El aparato eléctrico deberá ser conectado a una fuente de poder sólo del tipo descrito en el instructivo de operación, o como se indique en el aparato.

12. Precaución debe ser tomada de tal manera que la tierra física y la polarización del equipo no sea eliminada.
13. Los cables de la fuente de poder deben ser guiados de tal manera que no sean pisados ni pellizcados por objetos colocados sobre o contra ellos, poniendo particular atención a los contactos y receptáculos donde salen del aparato.
14. El equipo eléctrico debe ser limpiado únicamente de acuerdo a las recomendaciones del fabricante.
15. En caso de existir, una antena externa deberá ser localizada lejos de las líneas de energía.
16. El cable de corriente deberá ser desconectado del cuando el equipo no sea usado por un largo periodo de tiempo.
17. Cuidado debe ser tomado de tal manera que objetos líquidos no sean derramados sobre la cubierta u orificios de ventilación.
18. Servicio por personal calificado deberá ser provisto cuando:
 - A: El cable de poder o el contacto ha sido dañado; u
 - B: Objetos han caído o líquido ha sido derramado dentro del aparato; o
 - C: El aparato ha sido expuesto a la lluvia; o
 - D: El aparato parece no operar normalmente o muestra un cambio en su desempeño; o
 - E: El aparato ha sido tirado o su cubierta ha sido dañada.

TRADEMARKS USED IN THIS MANUAL

AT and IBM are registered trademarks of International Business Machines Corporation.

Any other trademarks mentioned in this manual are acknowledged to be the property of the trademark owners.

Contents

Chapter	Page
1. Specifications	6
2. Introduction	7
3. Installation	8
3.1 Jumper and Switch Configuration	8
3.1.1 DTE/DCE Configuration	8
3.1.2 Frame Ground/Signal Ground	8
3.1.3 Full/Half-Duplex Operation	8
3.1.4 CTS Delay (W9 Jumper)	10
3.1.5 RS-485 Driver Enable (W15)	10
3.1.6 Half-Duplex Turnaround Delay	11
3.1.7 RS-485 Interface Terminated or Unterminated	11
3.1.8 Normal/Loopback Operation	12
3.1.9 RS-485 Interface Line Biased (Fail-Safe)	12
3.2 DCE/DTE Configuration	13
3.3 Typical Applications	21
Appendix: Pinning	27
Quick Reference: User-Selectable Options	29

1. Specifications

Optical Isolation: IC109A-R2, IC109AE, IC109C only

Interface: (1) asynchronous RS-232 port (DTE/DCE selectable); (1) asynchronous RS-485 port with improved surge protection and switch-selectable line termination or line bias

Pins Supported: RS-232 port: TD, RD, RTS, CTS, CD, DTR, DSR, SG, and FG;
RS-485 port: TXA, TXB, RXA, RXB

Data Rate: Up to 115 kbps, transparent to data

Connectors: (1) DB25 female RS-232 port; (1) four-wire terminal block (TB1)
RS-485 port

Operation: Point-to-point or multipoint; Full or half-duplex; Transparent to data;
Selectable RTS-to-CTS delay with option to inhibit CTS if CD is present (DCE);
DTE or DCE configurable RS-232 port; Normal or loopback operation

Timeout Delay: 0.15, 0.7, 2, 7, or 70 msec (for the RS-485 driver enabled by data feature)

Indicators: (5) LEDs: TX, RX, RTS, CD, and PWR

Temperature Tolerance: *Operating:* 32 to 122°F (0 to 50°C); *Storage:* -4 to +158°F (-20 to +70°C)

Humidity: Up to 95% relative humidity, noncondensing

MTBF: Approximately 180,000 hours (ground benign environment)

Power: PS154 (for use with IC108A, IC109A-R2): *Input:* 120 V, 60 Hz, 20 W;
Output: AC 17 VCT, 0.7 A; PS154E (for use with IC108AE, IC109AE): *Input:* 230 V,
50 Hz, 20 W; *Output:* AC 17 VCT, 750 mA

Size: Standalone Unit: 1.8"H x 5.5"W x 8.5"D (4.6 x 14 x 21.6 cm);
Rackmount Card: 7.4"L x 4.7"W (18.8 x 11.9 cm); 0.6 inches thick (1.5 cm)

Weight: Standalone Unit: 1 lb. (0.5 kg); Power supply only: *PS154:* 0.4 lb. (0.2 kg),
PS154E: 1.1 lb. (0.5 kg)

2. Introduction

The RS-232↔485/422 Converter Plus is an interface converter that changes the electrical characteristics from a non-balanced data standard (RS-232) to a balanced data standard (RS-422 or RS-485). The unit does not change/manipulate the actual data that passes through the unit. For example, this would be useful in an industrial application where RS-485 or RS-422 devices would need to be connected to an RS-232 device.

The RS-232↔485/422 Converter Plus is an RS-232-to-RS-485 interface converter that can be used in pairs to operate in the same manner as a line driver. It allows an RS-232 device to transmit data over much longer distances than is normally possible. Depending on the operating environment, as many as 64 devices can be linked together using twisted-pair cable.

The opto-isolating models (IC109A-R2, IC109AE, IC109C) protect equipment from differences in ground potentials on one side of the unit to the other side of the unit. Inside the RS-232↔485/422 Opto-Isolator/Converter, optical isolation circuitry converts electrical signals to light and back again, to keep signal noise and ground loops from crossing between segments of your RS-485 installation. That means the electrical noise from your factory floor won't affect your office communications, and the difference in ground potential between buildings won't damage your sensitive equipment.

The RS-232↔485/422 Converter is available in standalone and rackmount versions. The rackmount cards (part numbers IC108C and IC109C) are designed to be installed in the multi-function rack (part number RM005).

If you ordered the IC109A-R2, you should have received a cable and an adapter with your RS-232↔485/422 Converter Plus. The cable is designed to plug into an IBM® PC AT® (or clone) DB9 com port. The adapter is designed to be used with the supplied cable to connect to an IBM PC computer's DB25 com port.

Additional features include a manual loopback test to check the system wiring for both the RS-232 and RS-485 interfaces.

3. Installation

This section describes the jumper and switch functions for configuring the RS-232↔485/422 Converter. See Figure 1 on the next page for the component locations.

To install your RS-232↔485/422 Converter:

1. Set each of the ten jumpers/switches for your application.
2. Connect the RS-232↔485/422 Converter devices together as shown in Figures 5 through 8 (pages 22–24).
3. Apply power. (PS154 or PS154E, depending on which RS-232↔485/422 Converter you have. See **Chapter 1** for more information.)

3.1 Jumper and Switch Configuration

NOTE

As you read this section, refer to Tables 1 and 2. Table 1 (page 14) lists DCE jumper settings, and Table 2 (page 19) lists DTE jumper settings.

3.1.1 DTE/DCE CONFIGURATION

A DIP shunt is used to select DTE or DCE configuration. For the RS-232↔485/422 Converter to appear as a DTE device, put the DIP shunt jumper in socket XW1B. For the RS-232↔485/422 Converter to appear as a DCE device, put the DIP shunt jumper in socket XW1A.

3.1.2 FRAME GROUND/SIGNAL GROUND

Jumper W7 ties signal ground to frame ground. The position is left open at the factory. If signal ground is to be connected to frame ground, solder a 100-ohm, ½-watt resistor in location W7. A wire jumper may also be used. Care must be taken to ensure that ground circulating currents are limited to acceptable levels.

3.1.3 FULL/HALF-DUPLEX OPERATION

Jumper W8 selects full or half-duplex operation. Set W8 to the HALF position (B-C position) for half-duplex operation. Set W8 to the FULL position (A-B position) for full duplex operation.

NOTE

When the jumper W9 (CTS) is in the ON position and jumper W15 is in the A-B position, the RS-485 driver is always turned on to enable transmission of data. Therefore, half-duplex transmission cannot be performed. See Section 3.1.5 for an explanation of the the RS-485 driver.

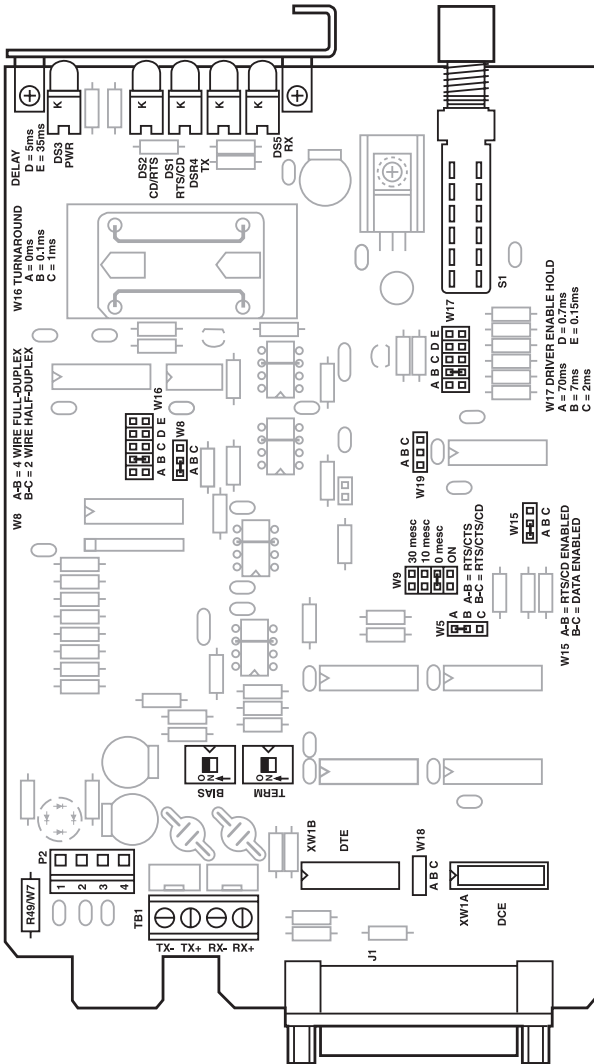

Figure 1. Layout of the Printed Circuit Board.

3.1.4 CTS DELAY (W9 JUMPER)

When the transmitter of a device is first turned on, an unstable carrier signal is transmitted for several milliseconds. If data was sent during this period, it would be received as distorted information. Setting a CTS delay on the RS-232↔485/422 Converter allows the communications link to settle down before data can be sent.

RS-232↔485/422 Converter as DCE (XW1A 8-Position Shunt)

When the RS-232↔485/422 Converter is configured as a DCE device (DIP shunt in position XW1A), jumper W9 controls the amount of delay from the time RTS (jumper W5 in the A-B position) is received true until CTS is asserted true. If W5 is in the B-C position, CTS will be inhibited if an RS-485 carrier is present when RTS is raised. To select a CTS delay period, set jumper W9 to the 0-, 10-, or 30-msec position. Regardless of the delay setting selected, when RTS goes false, CTS will immediately go false. If jumper W9 is in the “ON” position, CTS is held at +5 VDC.

RS-232↔485/422 Converter as DTE (XW1B 8-Position Shunt)

When the RS-232↔485/422 Converter is configured as a DTE device (DIP shunt in position XW1B), CTS is not supported.

3.1.5 RS-485 DRIVER ENABLE (W15)

The RS-232↔485/422 Converter’s RS-485 driver can be set to be enabled one of three ways: 1) by RS-232 control signals, 2) by data, or 3) constantly on via setting W9 in the ON position.

Driver Enabled by RS-232 Control Leads

If your equipment raises CD or RTS when it is ready to send data, you can set the RS-485 driver to be enabled by one of these leads. If your equipment does not have the capability to raise CD or RTS, you will need to set the RS-485 driver to be enabled by data or constantly enabled.

In order for an RS-232 control lead to enable the RS-485 driver, W15 must be in position A-B and W9 must be set for 0, 10, or 30 ms.

- When the RS-232 port is selected as DTE (DIP shunt in the XW1B position), the RS-485 driver will be enabled when CD (pin 8 of the RS-232 connector) goes true.
- When the RS-232 port is selected as DCE (DIP shunt in the XW1A position), RTS enables the driver.

Driver Enabled by Data

The RS-485 driver can also be enabled without requiring an RS-232 control lead to be asserted. When jumper W15 is placed in the B-C position, the driver is enabled when data is received on the RS-232 port of the RS-232↔485/422 Converter. As soon as the first bit of the first character is received at the RS-232 port, the RS-485 driver is enabled and an internal timer is started. The timer begins its “time out” on a low (0) to high (1) transition of data. When the timer times out, the RS-485 driver is disabled. Jumper W17 allows this timeout delay to be set for 0.15, 0.7, 2, 7, or 70 msec.

NOTE

There is a limitation to using this “DATA ENABLES DRIVER” feature. At data rates above 64 kbps, the first character in the data stream will be garbled by the converter. If higher data rates are required, transmit a <break> if possible, or a <nul> character before each message. This will enable the RS-485 driver, activate the timer, and allow the message to be transmitted without errors. The receiving device will need to ignore the first character received.

Driver Constantly Enabled (4 Wire Only)

The RS-485 driver can be constantly enabled by setting jumper W9 to the ON position.

3.1.6 HALF-DUPLEX TURNAROUND DELAY

When operating in half-duplex mode (jumper W8 in the HALF position [B-C position]), the RS-232↔485/422 Converter adds a small delay each time it stops transmitting data and prepares to receive data. This delay allows the RS-485 interface and transmission line time to stabilize, thus reducing the possibility of garbled data being received at the end of a message.

The turnaround delays are 0 (W16 in position A), 0.1 msec (W16 in position B), 1 msec (W16 in position C), 5 msec (W16 in position D), and 35 msec (W16 in position E).

3.1.7 RS-485 INTERFACE TERMINATED OR UNTERMINATED

Some distortion on the twisted-pair line may be caused by impedance mismatch from the different devices connected to the line. To help eliminate this type of distortion, the RS-485 interface can be terminated with a resistor network at the receiver input pins (RXA and RXB) via switch S2. When S2 is placed in the “TERM” position, the resistor network is connected across the line. When S2 is placed in the “UNTERM” position, no connection to the resistor network is made and the line is not terminated.

Point-to-Point

When only two devices are connected to the line in a point-to-point application, each device should have the termination network connected to the line. Set switch S2 to the “TERM” position (see Figures 5 and 6).

Multipoint

For multipoint applications, switch S2 should be in the “UNTERM” position on all the RS-232↔485/422 Converter devices in the network except for the two units at the extreme opposite locations on the line. The extreme opposite devices are the two devices that have the greatest cable length between them, which may not necessarily be the devices that are physically located the farthest apart. These two units should be set in the “TERM” position (see Figure 7). If any of the other RS-232↔485/422 Converters were configured as “terminated,” the amount of distortion could increase—possibly causing errors in the data being transmitted.

3.1.8 NORMAL/LOOPBACK OPERATION

The Normal/Loopback switch (S1) is a two-position pushbutton switch extending through the front panel. The Normal position permits normal operation of the RS-232↔485/422 Converter. The Loopback position allows data coming into the RS-232↔485/422 Converter to be sent back out the same port. This is for testing the connection between the RS-232↔485/422 Converter and the device attached to each port.

Normal

When this switch is in the normal mode, data is passed through the Converter from the RS-232 port to the RS-485 port and vice versa.

Loopback

When set to the loopback mode, any data received at the RS-485 port will be transmitted back out the RS-485 port and any data received at the RS-232 port will be transmitted back out the RS-232 port.

3.1.9 RS-485 INTERFACE LINE BIASED (FAIL-SAFE)

If S3 is in the Off position, there is no line bias. If S3 is in the On position, there is line bias. Setting to the on position will help stabilize the RS-422/RS-485 data lines. This is useful if there is noise on the data lines.

3.2 DCE/DTE Configuration

This section contains block diagrams (Figures 2 and 4) and jumper and switch settings (Tables 1 and 2) for DCE/DTE operation. For a detailed description of the jumpers and switches, see **Section 3.1**.

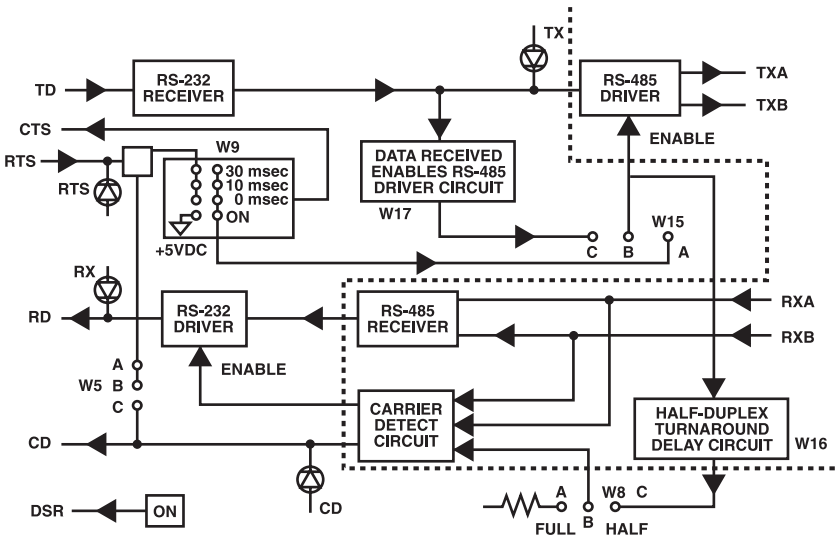

Figure 2. Simplified Functional Block Diagram (DCE Operation).

Table 1. DCE Jumper Settings.**NOTE**

For additional information on the jumper requirements, see Section 3.1.

Function	Jumper Requirements
1. Configure RS-232 port as DCE	XW1 in A position
2. Signal ground connected to frame ground	W7 is IN (solder your own 100-ohm, 1/2-watt resistor in place)
• Connected	
• Not connected	W7 is OUT
3. Full or half-duplex operation	W8 in FULL position (4 wire, A-B)
• Full duplex	
• Half-duplex	W8 in HALF position (2 wire, B-C)
4. CTS delay	W9 in 0-ms position W9 in 10-ms position W9 in 30-ms position
• Yes	
• No	W9 in ON position (no delay, CTS held to +5 VDC)

Table 1 (continued). DCE Jumper Settings.

Function	Jumper Requirements
<p>5. Enable RS-485 driver</p> <p>a. RS-485 driver enabled by RS-232 control leads</p> <ul style="list-style-type: none"> • by RTS <p>See Section 3.1.5 for more information.</p>	<p>W15 in A-B position and W9 in 0-ms position W9 in 10-ms position W9 in 30-ms position</p>
<p>b. RS-485 driver enabled by data</p> <p>How long the TX stays active after data is received on the RS-232 port (see Section 3.1.5).</p>	<p>W15 in B-C position and W17 msec</p> <p>A 70-ms position B 7-ms position C 2-ms position D 0.7-ms position E 0.15-ms position</p>
<p>c. RS-485 driver constantly enabled (see Section 3.1.5).</p>	<p>W9 in ON position</p>
<p>6. Half-duplex turnaround delay</p> <ul style="list-style-type: none"> • 0-msec turnaround delay 	<p>W8 in HALF (B-C) position and W16 in position A</p>
<ul style="list-style-type: none"> • 0.1-msec turnaround delay 	<p>W16 in position B</p>
<ul style="list-style-type: none"> • 1-msec turnaround delay 	<p>W16 in position C</p>
<ul style="list-style-type: none"> • 5-msec turnaround delay 	<p>W16 in position D</p>
<ul style="list-style-type: none"> • 35-msec turnaround delay (see Section 3.1.6). 	<p>W16 in position E</p>

Table 1 (continued). DCE Jumper Settings.

Function	Jumper Requirements				
7. RS-485 interface terminated or unterminated <ul style="list-style-type: none"> • Terminated 	S2 in TERM position (ON)				
<ul style="list-style-type: none"> • Unterminated See Section 3.1.7 for more information.	S2 in UNTERM position (OFF)				
8. Normal or loopback operation <ul style="list-style-type: none"> • Normal mode 	S1 in Normal position (released)				
<ul style="list-style-type: none"> • Loopback mode See Section 3.1.8 for more information.	S1 in Loopback position (pressed in)				
9. RS-485 Interface Line Biased (Fail-Safe), Receive See Section 3.1.9 for more information.	<table style="width: 100%; border: none;"> <tr> <td style="width: 50%;">S3 Off</td> <td style="width: 50%;">No line bias</td> </tr> <tr> <td>S3 On</td> <td>Line biased</td> </tr> </table>	S3 Off	No line bias	S3 On	Line biased
S3 Off	No line bias				
S3 On	Line biased				

NOTE

If line bias is on, the RS-485 CD will ALWAYS be on.

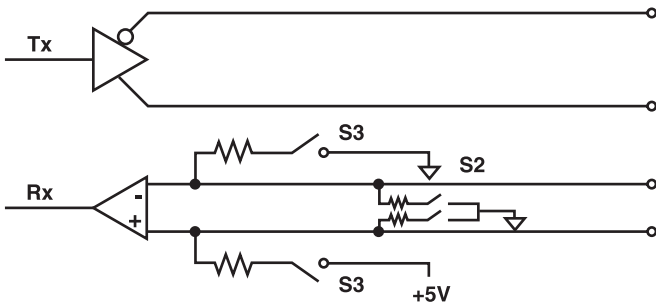

Figure 3. Line Bias. S2 shows the line termination when “Term” is selected. S3 shows line bias when “Bias” is selected.

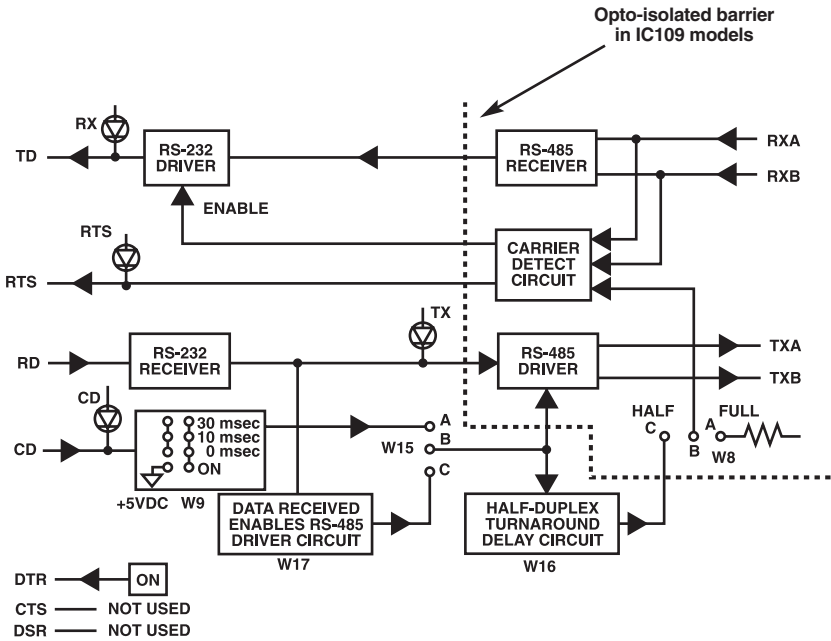

Figure 4. Simplified Functional Block Diagram (DTE Operation).

NOTE

The delay settings for W9 apply only to the CTS output of the RS-232↔485/422 Converter. Since CTS is not used when the RS-232↔485/422 Converter is configured as a DTE device, placing jumper W9 in either the 0-, 10-, or 30-msec position will allow the CD input to enable the RS-485 driver. When jumper W9 is in the ON position, the CD input has no effect on the RS-485 driver.

Table 2. DTE Jumper Settings.

NOTE

For additional information on the jumper requirements, see Section 3.1.

Function	Jumper Requirements
1. Configure RS-232 port as DTE	XW1 in B position
2. Signal ground connected to frame ground	W7 is IN (100-ohm, ½-watt resistor soldered in place)
<ul style="list-style-type: none"> • Connected 	
<ul style="list-style-type: none"> • Not connected 	
3. Full or half-duplex operation	W8 in FULL position (4 wire, A-B)
<ul style="list-style-type: none"> • Full duplex 	
<ul style="list-style-type: none"> • Half-duplex 	W8 in HALF position (2 wire, B-C)
4. CTS delay	CTS not supported
5. Enable RS-485 driver <ul style="list-style-type: none"> a. RS-485 driver enabled by RS-232 lead CD 	W15 in A-B position and W9 in 0-ms position W9 in 10-ms position W9 in 30-ms position

Table 2 (continued). DTE Jumper Settings.

Function	Jumper Requirements
b. RS-485 driver enabled by data <ul style="list-style-type: none"> • Disable timeout delay 	W15 in B-C position and W17 msec A 70 B 7 C 2 D 0.7 E 0.15
c. RS-485 driver constantly enabled	W9 in ON position
6. Half-duplex turnaround delay <ul style="list-style-type: none"> • 0-msec turnaround delay • 0.1-msec turnaround delay • 1-msec turnaround delay • 5-msec turnaround delay • 35-msec turnaround delay 	W8 in HALF position and W16 in position A W16 in position B W16 in position C W16 in position D W16 in position E
7. RS-485 interface terminated or unterminated	
<ul style="list-style-type: none"> • Terminated 	S2 in TERM position (ON)
<ul style="list-style-type: none"> • Unterminated 	S2 in UNTERM position (OFF)
8. Normal or loopback operation	
a. Normal mode	S1 in Normal position (Released)
b. Loopback mode	S2 in Loopback position (Pressed in)

Table 2 (continued). DTE Jumper Settings.

Function	Jumper Requirements	
9. RS-485 Interface Line Biased (Fail-Safe), Receive	S3 Off	No line bias
	S3 On	Line biased

NOTE

If line bias is on, the RS-485 CD will ALWAYS be on.

3.3 Typical Applications

This section describes some typical applications where the RS-232↔485/422 Converter might be used. The connections shown in the figures are for the RS-485 port.

Figure 5 shows a typical point-to-point, 4-wire, full or half-duplex connection with both RS-232↔485/422 Converters terminated by setting switch S2 to the TERM position. Figure 6 shows a typical point-to-point, 2-wire, half-duplex connection with both RS-232↔485/422 Converters terminated by setting switch S2 to the TERM position.

In a 4-wire, full-duplex, point-to-point application, each of the drivers on the two RS-232↔485/422 Converters may always be enabled without any adverse effects.

In a 2-wire, point-to-point or multipoint application, only one driver may be enabled at any one time. If more than one driver is turned ON, a situation known as contention occurs and the data from one driver interferes with the data from the other driver. This results in both sets of data being unintelligible or inhibits data flow altogether.

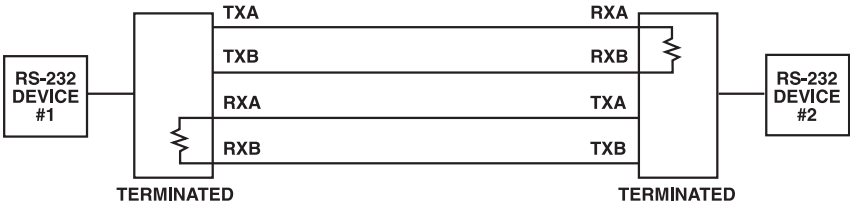

Figure 5. Point-to-Point, 4-Wire (Full or Half-Duplex).

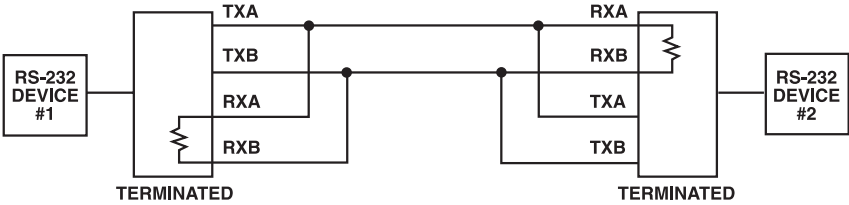

Figure 6. Point-to-Point, 2-Wire (Half-Duplex).

Figure 7 shows a typical multipoint, 4-wire, half-duplex connection. Figure 8 shows a typical multipoint, 2-wire, half-duplex connection. In the multipoint applications depicted in Figures 7 and 8, the devices at the extreme opposite ends of the installation are terminated by setting switch S2 to the TERM position. These devices are the two devices that have the greatest cable length between them, not necessarily the devices that are physically located the farthest apart. (See Figures 7 and 8.) A resistor shown in the circuit indicates that the termination resistor has been selected via switch S2. Note that although Figures 7 and 8 show only four RS-232↔485/422 Converter devices networked together, up to 64 units can be connected in the manner shown in Figure 7, and up to 32 units as shown in Figure 8.

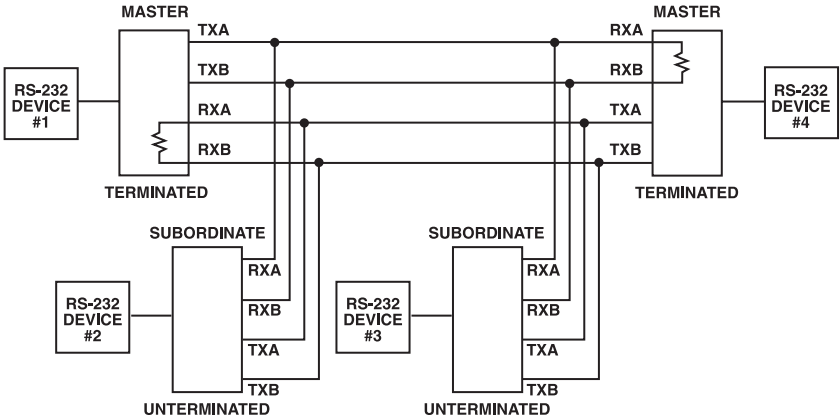

Figure 7. Multipoint, 4-Wire (Half-Duplex).

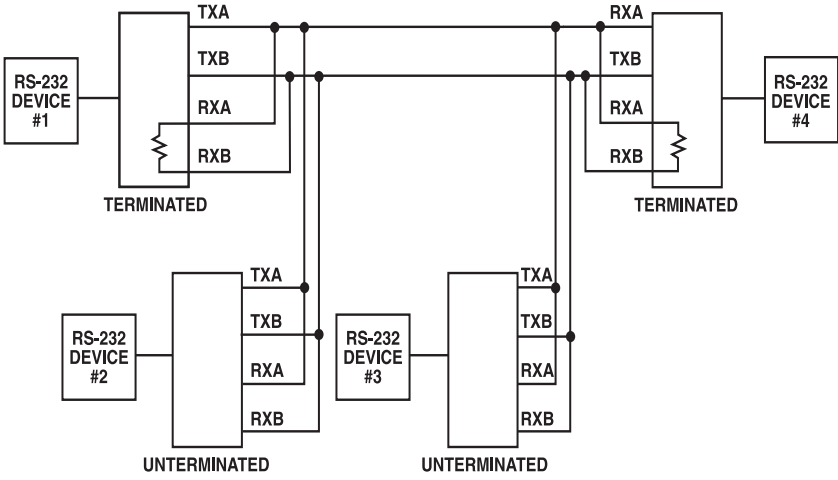

Figure 8. Multipoint, 2-Wire (Half-Duplex).

Example #1: 2-Wire Multipoint Configuration Using RTS Enable

In the following application, an industrial controller is used to gather information from several remote programmable logic controller (PLC) stations (see Figure 9). A system protocol has been defined such that all the programmable logic controllers receive the information sent by the industrial controller, but only the remote station specifically addressed will respond. In this system, the industrial controller and all the remote stations are DTE devices. The step-by-step installation procedure follows Figure 9.

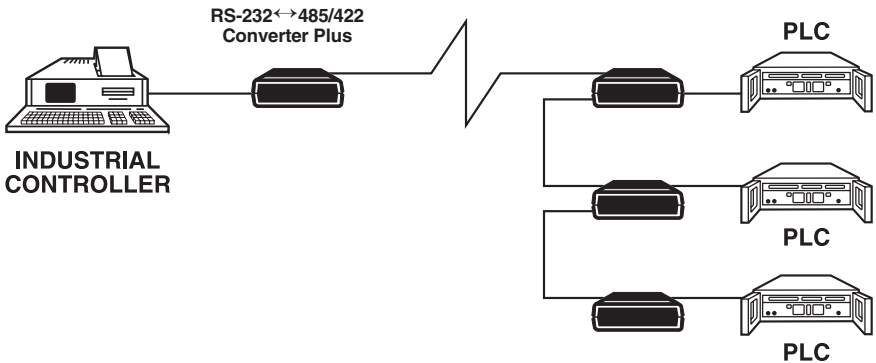

Figure 9. Sample Multipoint Operation.

Installation Procedure for the Multipoint Application in Figure 9

1. Set all the RS-232↔485/422 Converters for DCE operation (jumper XW1 in position A).
2. Connect a straight-through cable from the RS-232 port on each RS-232↔485/422 Converter to the RS-232 port on each of the PLCs.
3. Set all the RS-232↔485/422 Converters for normal operation (switch S1 [the loopback switch] in the “Normal” position).

4. After a remote station has been addressed, data transmission can occur between that station and the industrial controller until the industrial controller sends a “CLEAR” command. This command causes the remote PLC to resume data logging while waiting to be addressed again. In this application, set each RS-232↔485/422 Converter for half-duplex operation (jumper W8 in the “HALF” [B-C] position).
5. Connect the RS-232↔485/422 Converters together via a 2-wire twisted-pair cable (see Figure 7).
6. Terminate (switch S2 in the TERM position) the two RS-232↔485/422 Converters that have the greatest cable run between them and leave the others unterminated (switch S2 in the UNTERM position).
7. Since all the remote PLC stations must be inactive until addressed, the RS-485 driver of each remote RS-232↔485/422 Converter must not be constantly enabled (W9 of each remote RS-232↔485/422 Converter must be set to a position other than ON—30-, 10-, or 0-msec delay). The remote PLCs are fairly far from the industrial controller in our example, so it would be wise to set the CTS Delay (jumper W9) for 10 msec. This allows the line to stabilize after a remote PLC becomes active but before it starts to transmit.
8. Set jumper W9 on the RS-232↔485/422 Converter connected to the industrial controller to a delay of 30, 10, or 0 msec.
9. Set jumper W15 of each remote RS-232↔485/422 Converter and the master RS-232↔485/422 Converter to the A-B position. This allows the RS-485 driver to be enabled via the RS-232 control lead (in our example, RTS).
10. Jumper W16 is only used in 2-wire mode. W17 is only used in data enable mode. See Table 1. Typically, the default settings are fine.
11. This completes the configuration procedure. The system can now be activated.

Appendix. Pinning

Table 3. RS-232 Interface
(* Denotes Pins Used).

Pin	Circuit	Description	Signal Type	Direction when configured as	
				DCE	DTE
1*	AA	Protective Ground	Ground	—	—
2*	BA	Transmitted Data	Data	Input	Output
3*	BB	Receive Data	Data	Output	Input
4*	CA	Request to Send	Control	Input	Output
5*	CB	Clear to Send	Control	Output	Not connected
6*	CC	Data Set Ready	Control	Output (held high)	Not connected
7*	AB	Signal Ground	Ground	—	—
8*	CF	Data Carrier Detect	Control	Output	Input

NOTE

Pins 9 through 25 are not used.

Table 4. RS-485 Pinning Chart.

Pin Name	Description
TXA and TXB TXA=TX- TXB=TX+	Data received by the RS-232 [↔] 485/422 Converter at the RS-232 port is transmitted out of the unit over twisted-pair wires via these two outputs. The TX LED indicates the state of these two leads. When the TXA lead is positive with respect to the TXB lead (a “zero” being transmitted), the TX LED is lit.
RXA and RXB RXA=RX- RXB=RX+	These are the received data inputs for the RS-485 port. The status of these leads is monitored by the RX LED. When the RXA lead is positive with respect to the RXB lead (a “zero” is being received), the RX LED is lit.

Quick Reference: User-Selectable Options

Use this list as a quick-reference guide when you need to change the jumper settings.

An asterisk (*) designates the factory-preset jumper settings.

XW1A DCE*

XW1B DTE

W8 A-B* 4-wire
B-C 2-wire

W15 A-B* RTS/CD enabled
B-C Data enabled (Maximum speed is 64K.)

W5 A-B* RTS/CTS* delay (normal)
B-C RTS/CTS/CD delay (CTS inhibited if CD is present when RTS is raised.)

W9 RTS/CTS delay (The time before the RS-485 driver is enabled and CTS is asserted after RTS is asserted. The RS-485 driver is always enabled.)
A 30 msec
B 10 msec
C* 0 msec
D ON

W17 When W15 is in the B-C (Data Enabled) position, this is the time the RS-485 driver remains enabled after a low-to-high transition on the DATA line to prevent disabling the driver in the middle of a character.
A 70 msec
B* 7 msec
C 2 msec
D 0.7 msec
E 0.15 msec

NOTE

This only pertains to the unit when it is in data enable mode.

W16	Turnaround delay (When W8 is in the B-C [2 wire] position, this is the time after the driver is disabled and before the receiver is enabled.)
A	0 msec
B*	0.1 msec
C	1 msec
D	5 msec
E	35 msec

NOTES

- This only pertains to the unit in 2-wire mode.**
- If the Converter is configured Data Enabled (W15, position B-C) and 2-wire (W8 position B-C), then delays from W17 and W16 are cumulative.**

S1	OUT*	Normal
	IN	Loopback
S2	OFF*	RS-485 Receiver Unterminated
	ON	RS-485 Receiver Terminated
S3	OFF*	Line Bias Off
	ON	Line Bias On (The Carrier Detect light will come on. Default is +5 volts.)
TB1	4-wire terminal block on unit	
	1	----- Rx ----- B+
	2	----- Rx ----- A-
	3	----- Tx ----- B+
	4	----- Tx ----- A-



© Copyright 2003. Black Box Corporation. All rights reserved.

1000 Park Drive • Lawrence, PA 15055-1018 • 724-746-5500 • Fax 724-746-0746