

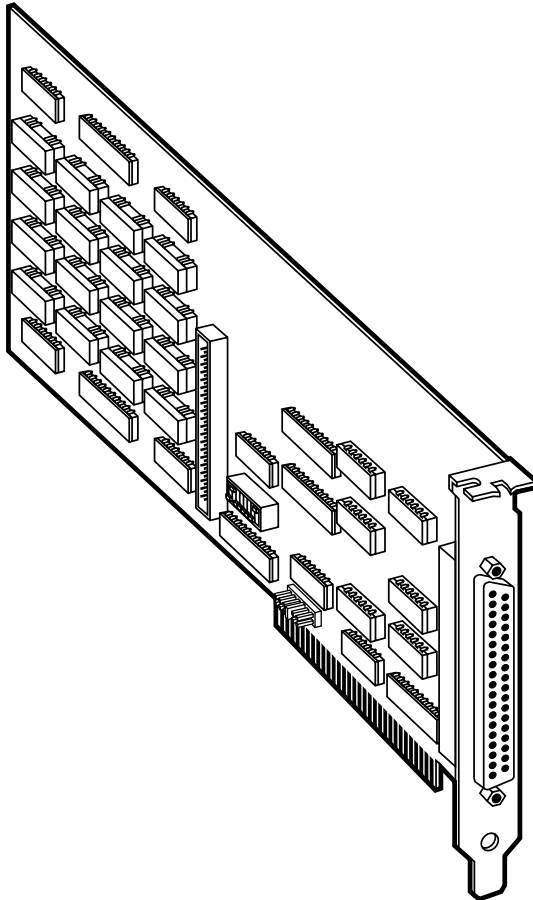

Relay/Digital I/O Card-16



**CUSTOMER
SUPPORT
INFORMATION**

Order toll-free in the U.S.: Call **877-877-BBOX** (outside U.S. call **724-746-5500**)
FREE technical support 24 hours a day, 7 days a week: Call **724-746-5500** or fax **724-746-0746**
Mailing address: **Black Box Corporation**, 1000 Park Drive, Lawrence, PA 15055-1018
Web site: www.blackbox.com • E-mail: info@blackbox.com

**FEDERAL COMMUNICATIONS COMMISSION
AND
INDUSTRY CANADA
RADIO FREQUENCY INTERFERENCE STATEMENTS**

This equipment generates, uses, and can radiate radio-frequency energy, and if not installed and used properly, that is, in strict accordance with the manufacturer's instructions, may cause interference to radio communication. It has been tested and found to comply with the limits for a Class A computing device in accordance with the specifications in Subpart B of Part 15 of FCC rules, which are designed to provide reasonable protection against such interference when the equipment is operated in a commercial environment. Operation of this equipment in a residential area is likely to cause interference, in which case the user at his own expense will be required to take whatever measures may be necessary to correct the interference.

Changes or modifications not expressly approved by the party responsible for compliance could void the user's authority to operate the equipment.

This digital apparatus does not exceed the Class A limits for radio noise emission from digital apparatus set out in the Radio Interference Regulation of Industry Canada.

Le présent appareil numérique n'émet pas de bruits radioélectriques dépassant les limites applicables aux appareils numériques de la classe A prescrites dans le Règlement sur le brouillage radioélectrique publié par Industrie Canada.

**NORMAS OFICIALES MEXICANAS (NOM)
ELECTRICAL SAFETY STATEMENT**

INSTRUCCIONES DE SEGURIDAD

1. Todas las instrucciones de seguridad y operación deberán ser leídas antes de que el aparato eléctrico sea operado.
2. Las instrucciones de seguridad y operación deberán ser guardadas para referencia futura.
3. Todas las advertencias en el aparato eléctrico y en sus instrucciones de operación deben ser respetadas.
4. Todas las instrucciones de operación y uso deben ser seguidas.
5. El aparato eléctrico no deberá ser usado cerca del agua—por ejemplo, cerca de la tina de baño, lavabo, sótano mojado o cerca de una alberca, etc..
6. El aparato eléctrico debe ser usado únicamente con carritos o pedestales que sean recomendados por el fabricante.
7. El aparato eléctrico debe ser montado a la pared o al techo sólo como sea recomendado por el fabricante.
8. Servicio—El usuario no debe intentar dar servicio al equipo eléctrico más allá a lo descrito en las instrucciones de operación. Todo otro servicio deberá ser referido a personal de servicio calificado.
9. El aparato eléctrico debe ser situado de tal manera que su posición no interfiera su uso. La colocación del aparato eléctrico sobre una cama, sofá, alfombra o superficie similar puede bloquea la ventilación, no se debe colocar en libreros o gabinetes que impidan el flujo de aire por los orificios de ventilación.
10. El equipo eléctrico deber ser situado fuera del alcance de fuentes de calor como radiadores, registros de calor, estufas u otros aparatos (incluyendo amplificadores) que producen calor.
11. El aparato eléctrico deberá ser conectado a una fuente de poder sólo del tipo descrito en el instructivo de operación, o como se indique en el aparato.

12. Precaución debe ser tomada de tal manera que la tierra física y la polarización del equipo no sea eliminada.
13. Los cables de la fuente de poder deben ser guiados de tal manera que no sean pisados ni pellizcados por objetos colocados sobre o contra ellos, poniendo particular atención a los contactos y receptáculos donde salen del aparato.
14. El equipo eléctrico debe ser limpiado únicamente de acuerdo a las recomendaciones del fabricante.
15. En caso de existir, una antena externa deberá ser localizada lejos de las líneas de energía.
16. El cable de corriente deberá ser desconectado del cuando el equipo no sea usado por un largo periodo de tiempo.
17. Cuidado debe ser tomado de tal manera que objetos líquidos no sean derramados sobre la cubierta u orificios de ventilación.
18. Servicio por personal calificado deberá ser provisto cuando:
 - A: El cable de poder o el contacto ha sido dañado; u
 - B: Objetos han caído o líquido ha sido derramado dentro del aparato; o
 - C: El aparato ha sido expuesto a la lluvia; o
 - D: El aparato parece no operar normalmente o muestra un cambio en su desempeño; o
 - E: El aparato ha sido tirado o su cubierta ha sido dañada.

TRADEMARKS USED IN THIS MANUAL

Windows and Windows NT are either registered trademarks or trademarks of Microsoft Corporation in the United States and/or other countries.

Any other trademarks mentioned in this manual are acknowledged to be the property of the trademark owners.

CE Compliance

Products bearing the CE label fulfill the requirements of the EMC directive (89/336/EEC) and of the low-voltage directive (73/23/EEC) issued by the European Commission.

To obey these directives, the following European standards must be met:

- **EN55022 Class A** — “Limits and methods of measurement of radio interference characteristics of information technology equipment.”
- **EN50082-1** — “Electromagnetic compatibility — Generic immunity standard.”
- Part 1: Residential, commercial, and light industry.
- **EN60950 (IEC950)** — “Safety of information technology equipment, including electrical business equipment.”

WARNING

This is a Class A Product. In a domestic environment this product may cause radio interference in which case you may be required to take adequate measures.

Always use cabling provided with this product if possible. If no cable is provided or if an alternate cable is required, use high-quality shielded cabling to maintain compliance with FCC/EMC directives.

Contents

Chapter	Page
1. Specifications	7
2. Introduction	8
2.1 Overview.....	8
2.2 What's Included	8
2.3 Factory-Default Settings	8
2.4 Technical Description.....	9
2.4.1 Features	9
2.4.2 Input Ports.....	10
2.4.3 Output Ports (Reed Relay).....	11
2.4.4 Relay Specifications.....	12
2.4.5 Programming Examples	13
3. Card Setup	14
3.1 Address Selection	14
3.2 IRQ Header E2	15
4. Installation	16
Appendix A. Troubleshooting	17
A.1 Calling Black Box	17
A.2 Shipping and Packaging	18
Appendix B. Block Diagram.....	19
Appendix C. Schematics.....	20

1. Specifications

Compliance:	CE approval; FCC Part 15, Class A
Channels:	32 (16 input, 16 output)
Input Range:	3 to 12 VDC AC/DC
Input Isolation:	Optical, 400 V
Output Relay:	200 million operations 10-VA resistive load
Throughput:	660 Hz (relay maximum operating speed)
Relay Contact Power Ratings:	10 W maximum
Relay Contact Voltage:	100 VDC or VAC maximum
Relay Contact Current:	0.5 A DC or AC RMS maximum
Relay Contact Resistance:	<i>Initial:</i> 0.15 ohms
Relay Rated Life:	<i>Low load:</i> 200,000,000 closures; <i>Maximum load:</i> 100,000,000 closures
Relay Contact Speed:	<i>Operate:</i> 0.5 milliseconds; <i>Release:</i> 0.5 milliseconds; <i>Bounce:</i> 0.5 milliseconds
MTBF:	>150,000 hours (calculated)
Connectors:	(1) DB37 male, (1) DB37 female
Temperature:	<i>Operating:</i> 32 to 122°F (0 to 50°C); <i>Storage:</i> -4 to +158°F (-20 to +70°C)
Humidity:	10 to 90% relative humidity, noncondensing
Power:	From the bus
Power Consumption:	<i>Supply line:</i> +5 VDC; <i>Rating:</i> 270 mA
Size:	4.2"H x 9.8"W (10.7 x 24.9 cm)

2. Introduction

2.1 Overview

The Relay/Digital I/O Card-16 provides 32 channels of isolated digital I/O for the PC. The card is designed with four ports containing 8 channels each. Ports A and B each offer 8 channels of optically isolated inputs. Each input is isolated from ground, from host PC ground, and from all other channels. Isolation is provided for up to 400 VDC. Ports C and D each offer 8 bits of reed-relay outputs for controlling the on/off status of external devices or other low-current-level applications. These ports have non-destructive read-back capability. Windows® 98/Me/XP, Windows NT®, and Windows 2000 drivers are included.

The Relay/Digital I/O Card-16 is PC compatible and fits any full-length ISA or EISA slot. Addressing, data, and control signals are TTL compatible.

2.2 What's Included

The Relay/Digital I/O Card-16 is shipped with the following items. If any of these items are missing or damaged, contact Black Box at 724-746-5500.

- Relay/Digital I/O Card-16
- 37-Pin Ribbon Cable
- Relay/Digital I/O Software (on a CD-ROM)
- User's manual

2.3 Factory-Default Settings

The factory-default settings are as follows:

Base Address	IRQ
300	5

To install the Relay/Digital I/O Card-16 using factory-default settings, refer to **Chapter 4**.

For your reference, record installed Relay/Digital I/O Card-16 settings below:

Base Address	IRQ

2.4 Technical Description

The Relay/Digital I/O Card-16 provides four parallel input/output (I/O) ports. The ports are organized as ports A, B, C, and D. Ports A and B are input ports interfaced to optically isolated inputs, while ports C and D are reed-relay output ports. Assuming an I/O address of 300 Hex, Table 2-1 lists the port addresses.

Table 2-1. Port addresses.

Base Address	Hex	Decimal	Mode
Port A Address	300	768	Input Port (Opto Input)
Port B Address	301	769	Input Port
Port C Address	302	770	Output Port (Reed Relays)
Port D Address	303	771	Output Port

2.4.1 FEATURES

- Selectable I/O port addressing from 100H to 3FFH.
- 2 sets of 8 Single-Pole, Single-Throw (SPST) relays.
- 2 eight-bit input ports.
- DB37 male connector for relay outputs.
- DB37 female connector for optically isolated inputs.
- Highly reliable 10-VA DIP reed relays used.
- 8-bit slot connector.
- Multiple adapters can reside in same computer.
- All address, data, and control signals are TTL compatible.

2.4.2 INPUT PORTS

Ports A and B are 8-bit input ports connected to optically isolated input sensors. Each sensor can be used to interface a voltage input and then sense whether the voltage is on or off. Each sensor is isolated (with respect to a common ground) from every other sensor, and also isolated with respect to the host PC ground. This means that signals such as low-level AC line voltage, motor servo voltage, and control relay signals can be “sensed,” or read by the PC, without the risk of damage due to ground loops or ground faults.

Each sensor input pair has a current-limiting resistor which is used to limit the input current to the opto-isolator. The opto-isolator has two “back-to-back” diodes internally. This allows AC or DC signals to be sensed, regardless of polarity. When the applied voltage is high enough to cause the LED in the opto-isolator to turn on, the opto-isolator’s output goes low (0 volts) and the signal is read as a low logic level (binary 0) by the PC. When the input signal is too low to turn on the opto-isolator, the output goes high and the port bit is read by the PC as a high logic level (binary 1).

Each isolated input’s input impedance is approximately 560 ohms (factory default). The opto-isolator requires approximately 3 mA to turn on. The maximum input current is 60 mA.

There are two things to consider when selecting the input resistor. The first is power-on voltage for the circuit to sense, and the second is the maximum input voltage. Maximum input voltage must not provide too much power to the input resistor, and must also not overdrive the opto-isolator’s input-current specification. The following formulas apply:

Power-on current: 3 mA
Isolator diode drop: 1.1 V
Resistor power max.: 0.25 W

Power-on voltage = diode drop + (power-on current) x (resistance)
Or :

$$1.1 + (0.003) \times R$$

Maximum voltage = square root of (0.25 [resistor value])

Table 2-2 shows four common input resistors and the ranges associated with each.

Table 2-2. Input resistors ranges.

Input Resistor (Ohms)	Value Power-On (Volts)	Max. Input Range (Volts)	Max. Current (mA)
220	1.76 to 7.4	2 to 6	29
560	2.8 to 11.8	3 to 12	19
1K	4.1 to 15	8.4 to 16	15
2.2K	7.7 to 23.4	8 to 24	10

The input circuits are not intended for monitoring 120-volt AC circuits. That would be too high a voltage for the circuits, and it is dangerous to have that high a voltage on the card. Table 2-3 shows the input circuits' pin assignments.

Table 2-3. Pin assignments for sensor input ports (P1).

Port A Bit	P1	Port B Bit	P1
0	18,37	0	10,29
1	17,36	1	9,28
2	16,35	2	8,27
3	15,34	3	7,26
4	14,33	4	6,25
5	13,32	5	5,24
6	12,31	6	4,23
7	11,30	7	3,22
Ground	2,20,21		
+ 12 volts	19		
+ 5 volts	1		

2.4.3 OUTPUT PORTS (REED RELAY)

Reed relays provide very-high-quality, long-life, low-current (10-watt maximum), dry-contact switch closures. Reed relays are not suited for high-current applications, and can be destroyed by inductive load switching, where a spark occurs across the contacts internally. The relays are normally open, and they close when energized. Each relay can be individually energized by writing a "1" to the proper port bit.

2.4.4 RELAY SPECIFICATIONS

- *Contact Power Ratings:* 10 watts maximum
- *Contact Voltage Maximum:* 100 volts DC or AC maximum
- *Contact Current Maximum:* 0.5 amps DC or AC RMS
- *Contact Resistance, Initial:* 0.15 ohms
- *Rated Life:*
 - Low Load:* 200 million closures
 - Maximum Load:* 100 million closures
- *Contact Speed:*
 - Operate:* 0.5 ms
 - Release:* 0.5 ms
 - Bounce:* 0.5 ms
- *Maximum Operating Speed:* 600 Hz

Table 2-4 lists the output ports' pin assignments.

Table 2-4. Pin assignments for output ports (reed relay) (P2).

Port C Bit	Relay	P2 Pin	Port D Bit	Relay	P2 Pin
0	K16	2,20	0	K8	10,28
1	K15	3,21	1	K7	11,29
2	K14	4,22	2	K6	12,30
3	K13	5,23	3	K5	13,31
4	K12	6,24	4	K4	14,32
5	K11	7,25	5	K3	15,33
6	K10	8,26	6	K2	16,34
7	K9	9,27	7	K1	17,35
Ground	18,36,37				
+ 5 volts	19				
+ 12 volts	1				

2.4.5 PROGRAMMING EXAMPLES

All examples assume a base address of 300 Hex.

To read inputs at port A :

```
MOV DX, 300H           ;Set DX to Port A
IN AL, DX              ;Get Input Port Data
NOT AL                 ;data read is negative logic
```

Programming example to set Relay #3 on, write a “1” in bit position D3, to port address Base+3, or 303 Hex.

```
MOV DX, 303H           ;Set DX to Port A
MOV AL, 00001000B     ;Set bit 3 to a “1”
OUT DX, AL
```

Another method that takes into account the read-back capability of the output ports C and D:

```
MOV DX, 303H           ;Set DX To Port C
IN AL, DX              ;Get old port setting
OR AL, 00001000B     ;OR in bit 3
OUT DX, AL            ;Set Bit 3
```

NOTE

Reading back the ports (C and D) results in the binary complement of the output.

3. Card Setup

The Relay/Digital I/O Card-16 contains several jumper straps per port that must be set for proper operation.

3.1 Address Selection

The Relay/Digital I/O Card-16 occupies four consecutive I/O locations. The DIP switch (SW1) is used to set the base address for these locations. Be careful when selecting the base address as some selections conflict with existing PC ports. Table 3-1 shows several examples that usually do not cause a conflict.

Table 3-1. Base address settings.

Address	Binary	Switch Settings							
		1	2	3	4	5	6	7	8
100–104	01 0000 00xx	Off	On	On	On	On	On	On	On
104–108	01 0000 01xx	Off	On	On	On	On	On	On	Off
200–204	10 0000 00xx	On	Off	On	On	On	On	On	On
280–283	10 1000 00xx	Off	On	Off	On	On	On	On	On
284–287	10 1000 01xx	Off	On	Off	On	Off	On	On	Off
2EC–2EF	10 1110 11xx	Off	On	Off	Off	Off	On	Off	Off
300–303	11 0000 00xx	Off	Off	On	On	On	On	On	On
320–323	11 0010 00xx	Off	Off	On	On	Off	On	On	On
388–38B	11 1000 10xx	Off	Off	Off	On	On	On	Off	On
3A0–3A3	11 1010 00xx	Off	Off	Off	On	Off	On	On	On
3A4–3A7	11 1010 01xx	Off	Off	Off	On	Off	On	On	Off

Figure 3-1 shows the correlation between the DIP-switch setting and the address bits used to determine the base address. In the example below, address 300 (the factory default) is selected as the base address. Address 300 in binary is XX 11 0000 00XX, where X is a non-selectable address bit and address bit A9 is always a 1.



Figure 3-1. DIP-switch illustration.

NOTE

Setting the switch ON (or Closed) corresponds to a “0” in the address, while leaving it OFF (or Open) corresponds to a “1.”

3.2 IRQ Header E2

Interrupts can be generated by Port A, bit 0 going low if enabled at jumper location E2. Interrupt request signals 2/9 through 7 (IRQ 2/9–7) can be selected by placing the jumper in the appropriate position. See Figure 3-2. Other inputs can be “wire ORed” to also generate interrupts you’d like. Call Technical Support for more information.



Figure 3-2. IRQ Header E2.

NOTE

The factory default is 5.

4. Installation

The Relay/Digital I/O Card-16 can be installed in any ISA or EISA PC expansion slot. Before you install the card, make sure you have followed the configuration instructions in **Chapter 3**.

To install the card:

1. Turn off all PC power and disconnect the power cord.
2. Remove the cover of the PC case.
3. Locate two available slots and remove the blank metal slot covers.
4. Gently insert the Relay/Digital I/O Card-16 into the slot. Make sure the card is seated properly. Insert the cable bracket into the adjacent slot and screw it in place.
5. Replace the PC's cover.
6. Connect the power cord.

Installation is complete.

Appendix A. Troubleshooting

1. Identify all I/O adapters currently installed in your system. This includes your onboard serial ports, controller cards, and sound cards.
2. Configure the Relay/Digital I/O Card-16 so that there is no conflict with currently installed adapters. No two adapters can occupy the same I/O address.
3. Make sure the card is securely installed in a motherboard slot.
4. Listed below are known I/O conflicts:
 - The 278 and 378 settings may conflict with your printer I/O adapter.
 - 3B0 cannot be used if a monochrome video adapter is installed.
 - 3F8–3FF is typically reserved for COM1:.
 - 2F8–2FF is typically reserved for COM2:.
 - 3E8–3EF is typically reserved for COM3:.
 - 2E8–2EF is typically reserved for COM4:.

A.1 Calling Black Box

If you determine that your Relay/Digital I/O Card-16 is malfunctioning, do not attempt to alter or repair the unit. It contains no user-serviceable parts. Contact Black Box at 724-746-5500.

Before you do, make a record of the history of the problem. We will be able to provide more efficient and accurate assistance if you have a complete description, including:

- the nature and duration of the problem.
- when the problem occurs.
- the components involved in the problem.
- any particular application that, when used, appears to create the problem or make it worse.

A.2 Shipping and Packaging

If you need to transport or ship your Relay/Digital I/O Card-16:

- Package it carefully. We recommend that you use the original container.
- If you are shipping the Relay/Digital I/O Card-16 for repair, make sure you include everything that came in the original package. Before you ship, contact Black Box to get a Return Authorization (RA) number.

Appendix B. Block Diagram

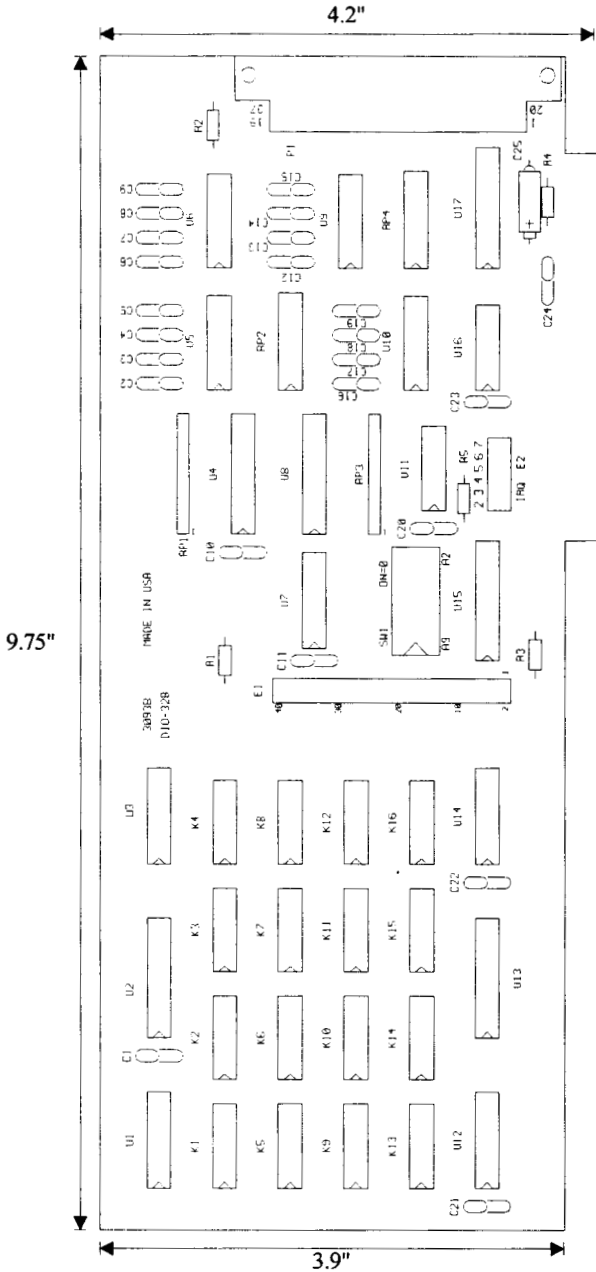

Appendix C. Schematics

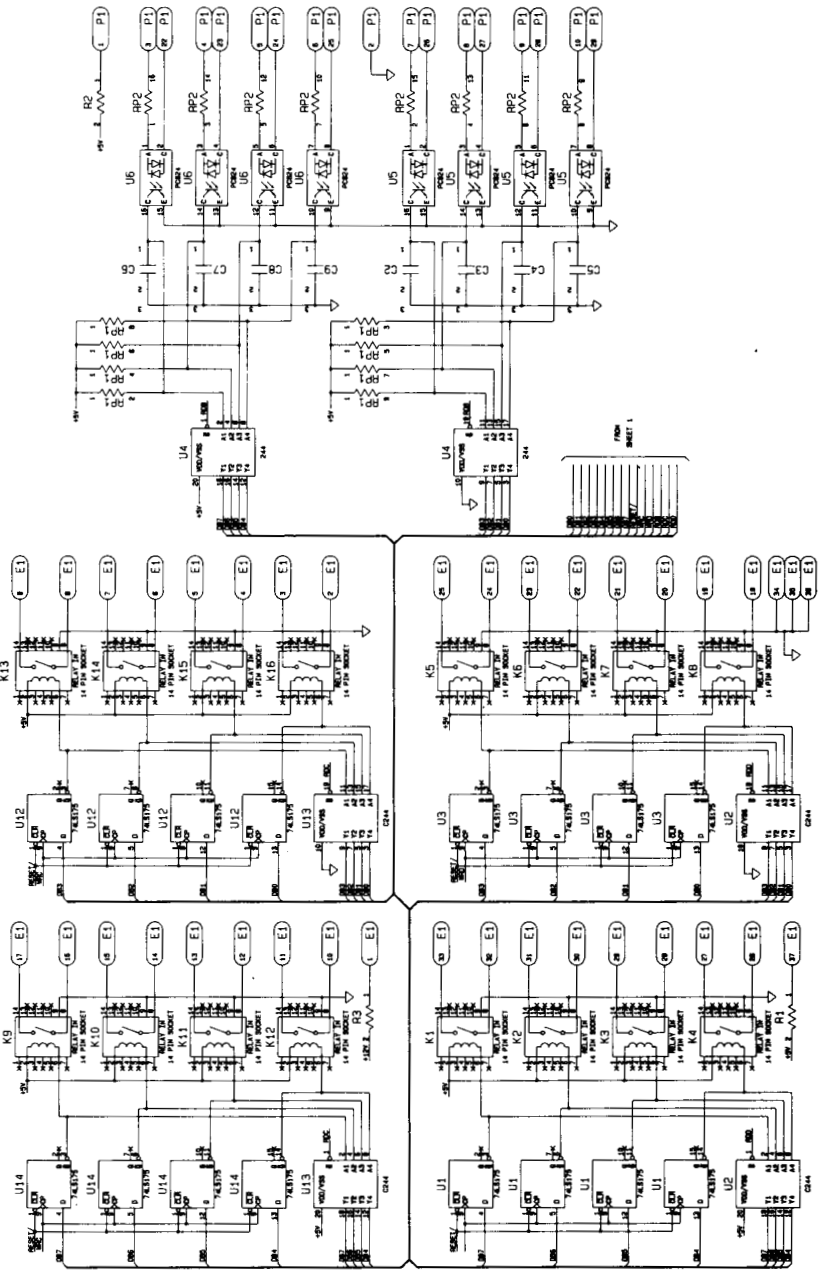

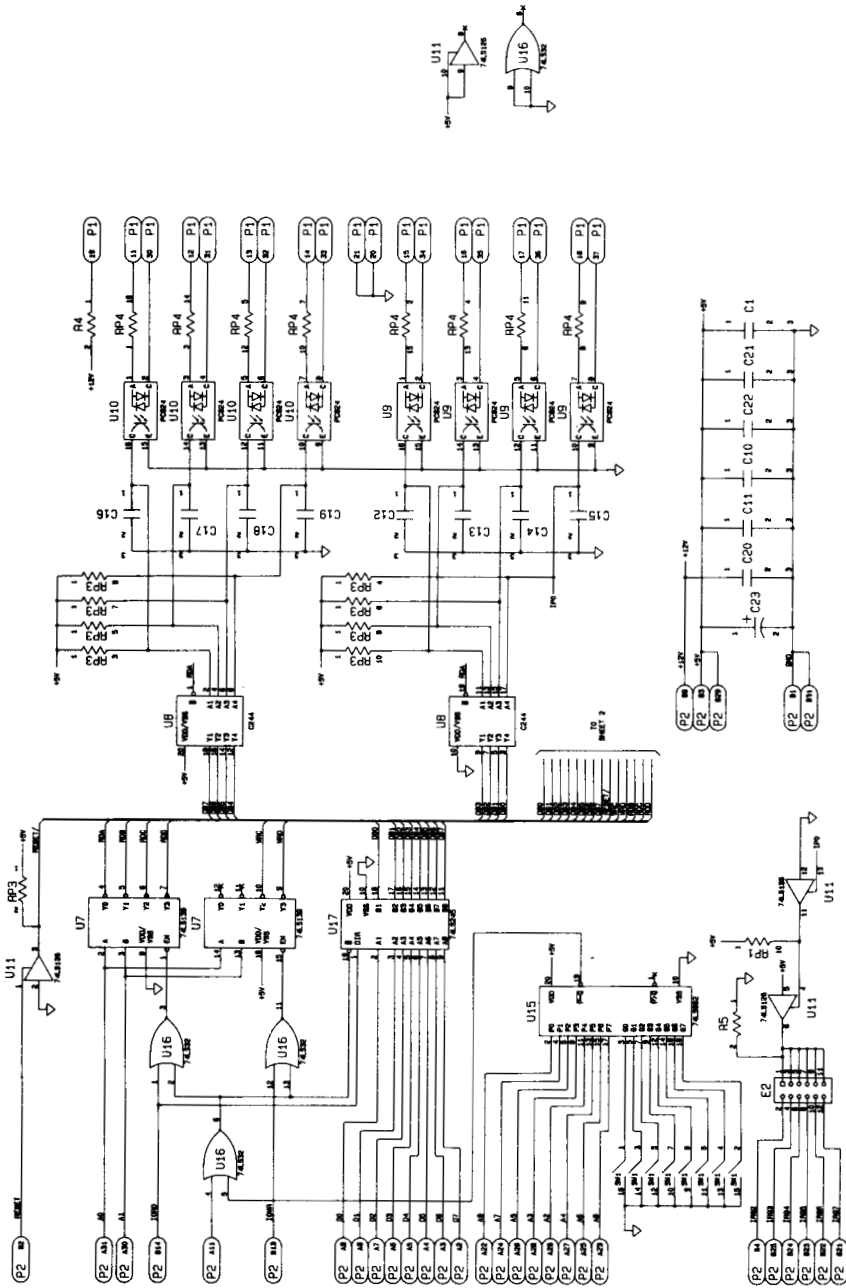



© Copyright 2005. Black Box Corporation. All rights reserved.

1000 Park Drive • Lawrence, PA 15055-1018 • 724-746-5500 • Fax 724-746-0746