

About BandwidthManager

BandwidthManager from Black Box is a two port ,10 Mbps Ethernet networking device that provides the ability to regulate bandwidth bi-directionally. It is available as a standalone unit or as an SNMP-manageable module to be used in conjunction with Black Box' SNMP-manageable media conversion chassis.

BandwidthManager features two RJ-45 data ports (labeled A and B), as well as a DB-9 serial port for IP configuration. Both RJ-45 ports may be configured for Half-Duplex (HDX) or Full-Duplex (FDX) operation (set this based on the capabilities of the connected hardware).

QUICK START	
DIP Switch Settings	1
Configuration Instructions	2
Serial Configuratio	3
About iView	5
Bandwidth Control	5
Packet Filtering	6
LEDs	6
Technical Support	9

DIP Switch Settings

You can set bandwidth of the data ports on *BandwidthManager* for any value up to 10 Mbps. The following instructions detail how to configure a *BandwidthManager* managed via **iView™**, an SNMP-compatible management application.

BandwidthManager is managed through its data ports. Before installing *BandwidthManager* into your network, you may want to change the device's default DIP switch settings which designate which port(s) will manage traffic (default settings shown in diagram below).

Refer to the figure below for DIP switch location and settings:

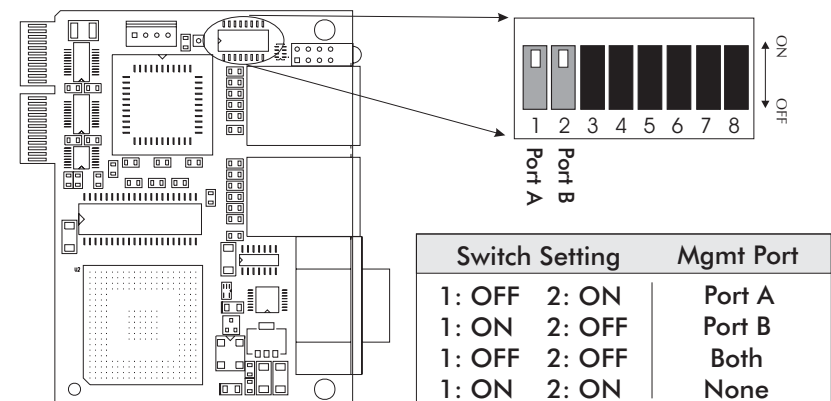

Within *iView*, you can set the bandwidth by clicking on the *Port A* or *Port B* tab. See the *iView for BandwidthManager* online help file for more information and assistance.

INSTALLING BANDWIDTHMANAGER

Installing *BandwidthManager* into a Black Box SNMP-Manageable media conversion chassis is simple. If necessary, remove the blank bracket covering the slot where you'll be installing the module. Slide the module into the chassis, then secure the module to the chassis by tightening the captive screws.

Configuring BandwidthManager

In order to configure and manage *BandwidthManager*, it is first necessary to give it an IP address so that it is accessible via SNMP. There are two ways to assign this IP information to *BandwidthManager*:

- using **HUBCTRL32™** through an Ethernet connection
- via the unit's serial port

Besides assigning an IP address and subnet mask, both methods will also allow you to create community strings, assign access rights, configure traps and more. However, *HUBCTRL32* offers more options than the serial port (e.g., you can select *which* traps to assign with *HUBCTRL32*).

ABOUT HUBCTRL32

HUBCTRL32 (Hub Control 32) is an in-band configuration utility that lets users quickly and easily complete the first stages of SNMP configuration for Black Box SNMP-manageable devices. Tasks *HUBCTRL32* can perform include:

- setting the IP address, subnet mask and default gateway
- defining the community strings and SNMP traps

In addition to the above functions, *HUBCTRL32* offers an authorized IP address system and access restriction to MIB groups supported by Black Box manageable devices. These extra layers of security are purely optional and do not effect SNMP compatibility in any way.

HUBCTRL32 can also be used to upload new versions of the system software and new MIB information. It also offers diagnostic capabilities for faster resolution of technical support issues.

HUBCTRL32 works with the following platforms:

- Windows 98™
- Windows NT™
- Windows 2000™

HUBCTRL32 can be found on the *iView* CD, or contact Black Box.

ELECTROSTATIC DISCHARGE PRECAUTIONS

Electrostatic discharge (ESD) can cause damage to your add-in modules. Always observe the following precautions when installing or handling an add-in module or any board assembly:

- 1) Do not remove unit from its protective packaging until you're ready to install it.
- 2) Wear an ESD wrist grounding strap before handling any module or component. If you do not have a wrist strap, maintain grounded contact with the system unit throughout any procedure requiring ESD protection.



WARNING! Integrated circuits and fiber optic components are extremely susceptible to electrostatic discharge damage. Do not handle these components directly unless you are a qualified service technician and use tools and techniques that conform to accepted industry practices.

- 3) Hold boards by the edges only; do not touch the electronic components or gold connectors.
- 4) After removal, always place the boards on a grounded, static-free surface, ESD pad or in a proper ESD bag. Do not slide the board over any surface.

FEDERAL COMMUNICATIONS COMMISSION RADIO FREQUENCY INTERFERENCE STATEMENT

This equipment has been tested and found to comply with the limits for a Class A computing device, pursuant to Part 15 of the FCC Rules. These limits are designed to provide reasonable protection against harmful interference when the equipment is operated in a commercial environment. This equipment generates, uses and can radiate radio frequency energy and, if not installed and used in accordance with the instruction manual, may cause harmful interference to radio communications. Operation of this equipment in a residential area is likely to cause harmful interference in which the user will be required to correct the interference at his own expense.

Any changes or modifications not expressly approved by the manufacturer could void the user's authority to operate the equipment.

The use of non-shielded I/O cables may not guarantee compliance with FCC RFI limits.

This digital apparatus does not exceed the Class A limits for radio noise emission from digital apparatus set out in the Radio Interference Regulation of the Canadian Department of Communications.

Le présent appareil numérique n'émet pas de bruits radioélectriques dépassant les limites applicables aux appareils numériques de classe A prescrites dans le Règlement sur le brouillage radioélectrique publié par le ministère des Communications du Canada.

WARRANTY

Please contact Black Box for complete warranty information.

For information regarding the installation and use of *HUBCTRL32*, refer to the *HUBCTRL32* installation guide or the *HUBCTRL32* online help file.

ABOUT SERIAL PORT CONFIGURATION

BandwidthManager's serial port uses an IBM-compatible DB-9 serial connector. To connect the device to your terminal/computer, use the enclosed DB-9 cable. (If your computer/terminal has a serial port using a connection not compatible with a DB-9 COM port, use the **Pin Connection** chart below for reference in making a cable.) Plug one end of the cable into the DB-9 connector on the device, and the other into the appropriate port on your computer/terminal. Set your computer/terminal for VT-100 emulation. The serial port on the computer/terminal should be set for:

- 38.4K baud
- 8 data bits
- 1 stop bit
- No parity
- No flow control

Pin #	Function
2	Transmit (OUT)
3	Receive (IN)
5	Ground
1,4, 6-9	Not Used

Main Configuration Screen

After running through an initial self test, the screen will display the following message: "Press <Enter> for Device Configuration." Press **Enter** to be taken to the main configuration screen and the following displays:

Saved Values — *displays changes made during current session.*

- IP Address (MUST be assigned during initial configuration)
- Subnet Mask (MUST be assigned during initial configuration)
- Default Gateway

Current Values — *displays values currently in use.*

- IP Address (IP address of SNMP agent)
- Subnet Mask (mask to define IP subnet agent is connected to)
- Default Gateway (default router for IP traffic outside subnet)

Command List

- **Space** = BandwidthManager Configuration
- **I** = Enter New Saved Parameter Values
- **C** = New Community String
- **U** = Delete ALL Community Strings
- **T** = New Trap Destination
- **K** = Remove ALL Trap Destinations
- **P** = Change Password
- **E** = End Session

N O T E

Because the Delete key does not work on VT-100 terminal emulators, use the **F2** key instead to perform Delete.

N O T E

You must reboot after making any modifications to the Saved Values or your changes will not take effect. To reboot, type the word "**Reboot**" (no quote marks) at the prompt on the main configuration screen, or turn the device's power OFF then ON again.

BandwidthManager Configuration

To configure *BandwidthManager*, press **Space** at the *Main Configuration Screen*, then type **bw**. This will enter the configuration program for *BandwidthManager*. To navigate in this program, press **Z** to move down, **W** to move up, **A** to move left, and **D** to move right. Pressing **Space** toggles between the *Bandwidth Control* section and the *Duplex Mode* section. Pressing **Q** exits the program.

To edit the data rate for each port, you can choose one of twelve predefined rates by moving the cursor to the rate you desire and pressing the **S** or **Enter** key, or enter your own rate by choosing **Custom**. To choose **Custom**, move the cursor to **Custom**, then press the **S** key. Enter a rate (between 64 bits/sec to 10,000,000 bits/sec in 1 bit/sec increments) and then press **Enter**. You can choose a rate for both *BandwidthManager* ports (from Port A to Port B and from Port B to Port A). Exit the program by pressing the **Q** key.

To change the Duplex setting, **Space** to toggle to the Duplex Setting section when, then press **S** or **Enter** to switch between Half- and Full-Duplex. The default setting for duplex on Ports A and B is Half-Duplex. Duplex can also be adjusted through *iView* by clicking on either *Port* tab.

Assigning IP Information

To modify the Saved Parameter Values (i.e., assign IP address and subnet mask), press **I**. You will be instructed to enter the IP address and subnet mask for the connected device. Press **Enter** after each. You may also assign a default gateway, if desired (press **Enter** to skip). When finished, press **Enter**, then type "**Reboot**" for changes to take effect. The Saved Values and Current Values should now both display the changes made (e.g., new IP address and subnet mask).

Troubleshooting

- ▶ Sometimes, depending on the speed of the management PC and/or its video card, the bandwidth displays in the Port A and Port B windows in *iView* may not update when switching between windows quickly. To update the display, click the **Refresh** button found in the upper-right corner of the window.
- ▶ The *iView* online help file requires Internet Explorer™ 4.0 service pack 2 or higher.

Should you encounter further difficulties, please contact Black Box technical support.

General Information

BLACK BOX TECHNICAL SUPPORT

Order toll-free in the U.S.: Call 877-877-BBOX (outside U.S. call 724-746-5500)
FREE technical support, 24 hours a day, 7 days a week:

Call: 724-746-5500

Fax: 724-746-0746

Mail order: Black Box Corporation, 1000 Park Drive,
Lawrence, PA 15055-1018

Web site: www.blackbox.com

E-mail: info@blackbox.com

SPECIFICATIONS

Environmental

Operating Temperature: 32° - 104° F (0° - 40° C)

Storage Temperature: 0° - 160° F (-20° - 70° C)

Humidity: 5 - 95% (non-condensing)

Electrical

Module: 5V ±5%, 0.5 Amp. (typical)

Configured: 100-240VAC ±10%, 0.2/0.1A

through 192.168.193.254, enter “192.168.193.0” for the Base IP. Then use the Range feature to block that range of addresses (enter “1” for Low and “254” for High).

- **Multiplexing Byte** — Tells *BandwidthManager* exactly which byte to multiplex the Base IP on (**A** for first, **B** for second, **C** for third, **D** for fourth) — wherever the first 0 appears. In the example above (see **Base IP**), the Multiplexing Byte would be **D**.
- **Range** — Tells *BandwidthManager* the **Low** and **High** of the range of IP addresses that should be discarded/forwarded (see **Base IP**).

Optional (depends upon individual network configuration):

- **Single IP** — A single IP address that will be excepted from the rule set up by the filtering mode. Typically, this is the address of the router itself.
- **Multicast** — Allows multicast traffic to pass when **Yes** is selected (default is **No**).
- **Broadcast** — Allows broadcast traffic to pass when **Yes** is selected (default is **No**). To enable, select **Yes**, then enter the subnet mask for the A and/or B nodes in the text box labeled “Broadcast Mask” within the appropriate port window in *iView*.

LED Indicators

BandwidthManager features status LEDs for each port (as shown below). The LED functions are:

- RCV** Blinks yellow when port is *receiving* data.
- XMT** Blinks green when port is *transmitting* data.
- FDX** Glows yellow when *Full-Duplex* mode is selected on port.
- LNK** Glows green when a *link* is established.

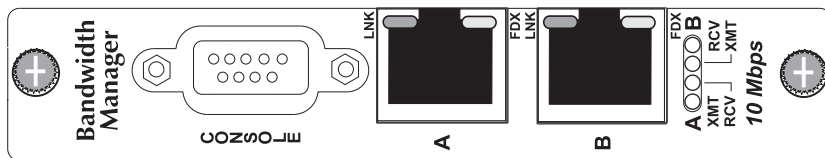

Creating/Deleting Community Strings

The default community string is named “public” and has read/write access. For security reasons, Black Box recommends you set up two communities: one with read-only access (for general use), the other with read/write access (for the administrator).

To create a new community string, go to the main configuration screen and press **C**. Enter the name of the new community (up to 16 characters, no spaces allowed) and press **Enter**. Then type one of the following options to assign the community string’s access rights:

- **R** = read-only access
- **W** = read/write access
- **Enter** = abort

Press **Enter**.

To delete all community strings and start over, press **U**. You will then be asked, “Are you sure you want to delete all future strings?” Press **Y** to proceed, **N** to abort. Press **Enter**. Note that the above function will delete ALL community strings. If you want to be able to selectively delete community strings, use *HUBCTRL32* to configure your device.

Assigning/Removing Trap Destinations

Traps are sent by the manageable device to a management PC when a certain event takes place. To enter a trap destination, press **T**. You will then be asked to “Enter a New IP Address.” Type the IP address of the destination device and press **Enter**. Then type the name of the community string (created earlier) and press **Enter**. All traps the device is capable of will be enabled. To remove ALL trap destinations, press **K**. You will then be asked if you really want to remove all trap destinations. Press **Y** to continue. Press **N** to abort. Press **Enter**.

Password Protection

You can password protect the serial configuration process by pressing **P** from the main configuration screen. You will be asked to enter a password. (**NOTE: Passwords are case sensitive.**) Enter your password (spaces are NOT allowed) and press **Enter**. You will then be asked for your password whenever you log on or off. To remove password protection, select **P** and instead of entering a password, press **Enter**. Should you forget the password, use *HUBCTRL32* to access the back-up copy of the PROM, then reburn the flash PROM (or contact Black Box technical support for assistance).

Ending Your Session

Be sure to press **E** before disconnecting the cable in order to stop the device from outputting to the serial port.

About iView

Once *BandwidthManager* is assigned an IP address, you can use *iView* or another SNMP-based Network Management System (NMS) application to configure and remotely manage *BandwidthManager*.

iView is a cross-platform network management application for Black Box intelligent networking devices. It gives network managers the ability to monitor and control Black Box' products from virtually any 32-bit Windows platform. *iView* can also function as a snap-in module for many SNMP applications. Please consult the *iView* installation guide or *iView* CD for assistance in installing and launching *iView*.

About Bandwidth Control

BandwidthManager has the ability to forward data in each direction (A to B and B to A) at up to 10 Mbps. You can set either or both directions to pass less than that (i.e., bandwidth control).

The bandwidth speed may be set independently for each port. As the actual Ethernet bit rate is always 10 Mbps, the bandwidth speed limitation for each port operates by extending the time between Ethernet packets so that the aggregate data rate matches the bandwidth setting. The algorithm used is intelligent enough to adjust "on-the-fly" to the length of each packet, resulting in a high degree of precision (within 5%).

To set the bandwidth via *iView*, simply input the desired bandwidth for this port in the *Bandwidth Control* section of the *Port* window (min: 64 bits/sec, max: 10,000,000 bits/sec). To set bandwidth via Serial Configuration, see the *Setting Bandwidth* on page 4.

Packet Filtering Modes

BandwidthManager provides six modes for forwarding/discarding frames that come in contact with the device which can be configured from the *Advanced Window* in *iView for BandwidthManager*. These packet filtering modes should be configured individually for each data port (A and B).

The first two modes, All Protocols (default) and IP/ARP Only, allow all or almost all network traffic to pass through *BandwidthManager*. These modes are used most often for traffic coming from the WAN or Internet, through the router and *BandwidthManager*, and on to the LAN. The other four modes use specific IP address ranges, defined by the user, to tell *BandwidthManager* to either pass on or discard traffic based upon its destination IP. These modes are either inclusionary or exclusionary, and are

most often used to restrict traffic coming from LAN, through *BandwidthManager*, and on to the router/Layer 3 device.

The six modes are as follows:

General Modes:

- **All Protocols** — Forwards ALL traffic. Can use this mode as a generic mode for incoming traffic to be forwarded on to the LAN.
- **IP/ARP Only** — Forwards all IP/ARP traffic; blocks all other protocols. Because this mode allows all IP/ARP traffic to pass through, this is the recommended mode for traffic coming from the Internet to the LAN.

Inclusionary Modes:

- **Non-IP/ARP, Plus IP/ARP Range** — Allows all non-IP traffic to pass; forwards only IP/ARP packets that fall into a specified range, discarding all other IP/ARP traffic.
- **IP/ARP Range Only** — Like previous mode, but blocks all non-IP traffic as well.

Exclusionary Modes:

- **All Protocols, Minus IP/ARP Range** — Forwards everything except what is specified in IP address range, including non-IP traffic.
- **IP/ARP Only, Minus IP/ARP Range** — Forwards all IP/ARP packets except what is specified in IP address range; discards non-IP traffic. Because this is the most efficient mode for blocking unnecessary traffic from reaching the router (unless using a non-IP protocol), this is the recommended mode for traffic coming from the LAN to the WAN/Internet.

Set the packet filtering mode based on the FIRST *BandwidthManager* port (Port A or Port B) the traffic will come in contact with.

ADDITIONAL CONFIGURATION FOR PACKET FILTERING MODES

When using an inclusionary or exclusionary mode, you will also need to enter values for the following:

Required (all inclusionary/exclusionary modes):

- **Base IP** — A four-byte address that tells *BandwidthManager* the common portion of the IP addresses for whose packets should be discarded (excluded) or forwarded (included), depending on mode. To specify the Base IP, place a "0" in each byte of the address which is NOT common to all packets. For example, if you want *BandwidthManager* to block traffic for IP addresses 192.168.193.1