

SME-NPR (LED)

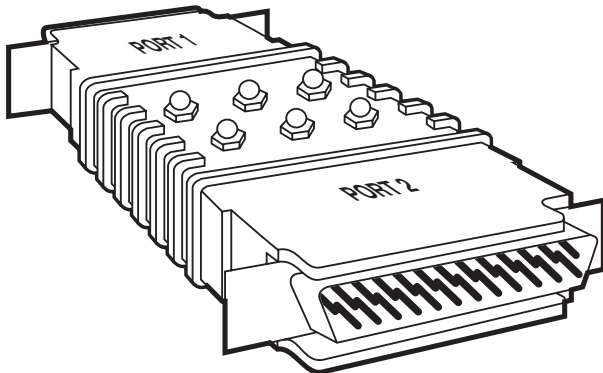

CUSTOMER SUPPORT INFORMATION

Order **toll-free** in the U.S.: Call **877-877-BBOX** (outside U.S. call **724-746-5500**)

FREE technical support 24 hours a day, 7 days a week: Call **724-746-5500** or fax **724-746-0746**

Mailing address: **Black Box Corporation**, 1000 Park Drive, Lawrence, PA 15055-1018

Web site: www.blackbox.com • E-mail: info@blackbox.com

**NORMAS OFICIALES MEXICANAS (NOM) ELECTRICAL SAFETY
STATEMENT**

INSTRUCCIONES DE SEGURIDAD

1. Todas las instrucciones de seguridad y operación deberán ser leídas antes de que el aparato eléctrico sea operado.
2. Las instrucciones de seguridad y operación deberán ser guardadas para referencia futura.
3. Todas las advertencias en el aparato eléctrico y en sus instrucciones de operación deben ser respetadas.
4. Todas las instrucciones de operación y uso deben ser seguidas.
5. El aparato eléctrico no deberá ser usado cerca del agua—por ejemplo, cerca de la tina de baño, lavabo, sótano mojado o cerca de una alberca, etc.
6. El aparato eléctrico debe ser usado únicamente con carritos o pedestales que sean recomendados por el fabricante.
7. El aparato eléctrico debe ser montado a la pared o al techo sólo como sea recomendado por el fabricante.
8. Servicio—El usuario no debe intentar dar servicio al equipo eléctrico más allá a lo descrito en las instrucciones de operación. Todo otro servicio deberá ser referido a personal de servicio calificado.
9. El aparato eléctrico debe ser situado de tal manera que su posición no interfiera su uso. La colocación del aparato eléctrico sobre una cama, sofá, alfombra o superficie similar puede bloquea la ventilación, no se debe colocar en libreros o gabinetes que impidan el flujo de aire por los orificios de ventilación.

10. El equipo eléctrico debe ser situado fuera del alcance de fuentes de calor como radiadores, registros de calor, estufas u otros aparatos (incluyendo amplificadores) que producen calor.
11. El aparato eléctrico deberá ser conectado a una fuente de poder sólo del tipo descrito en el instructivo de operación, o como se indique en el aparato.
12. Precaución debe ser tomada de tal manera que la tierra física y la polarización del equipo no sea eliminada.
13. Los cables de la fuente de poder deben ser guiados de tal manera que no sean pisados ni pellizcados por objetos colocados sobre o contra ellos, poniendo particular atención a los contactos y receptáculos donde salen del aparato.
14. El equipo eléctrico debe ser limpiado únicamente de acuerdo a las recomendaciones del fabricante.
15. En caso de existir, una antena externa deberá ser localizada lejos de las líneas de energía.
16. El cable de corriente deberá ser desconectado del cuando el equipo no sea usado por un largo periodo de tiempo.
17. Cuidado debe ser tomado de tal manera que objetos líquidos no sean derramados sobre la cubierta u orificios de ventilación.
18. Servicio por personal calificado deberá ser provisto cuando:
 - A: El cable de poder o el contacto ha sido dañado; u
 - B: Objetos han caído o líquido ha sido derramado dentro del aparato; o
 - C: El aparato ha sido expuesto a la lluvia; o
 - D: El aparato parece no operar normalmente o muestra un cambio en su desempeño; o
 - E: El aparato ha sido tirado o su cubierta ha sido dañada.

Contents

Chapter	Page
1. Specifications	5
2. Introduction	7
2.1 Description	7
2.2 Features and Benefits	8
3. Configuration	11
4. Installation and Operation	15
5. Troubleshooting	17
5.1 Calling Black Box	17
5.2 Shipping and Packaging	18
Appendix A: Block Diagram	19

1. Specifications

Interface	EIA RS-232C/CCITT V.24, both ports DCE
Protocol	Synchronous
Clock Source	Internal or external from Port 1 (user-selectable)
Data Rate	From internal clock: 1200, 2400, 4800, 9600, 19,200, or 38,400 bps (user-selectable); up to 38,400 bps from external clock
Maximum Distance ...	Under ideal conditions, 600 feet (182.9 meters)—up to 300 feet (91.4 meters) on either side of the unit—at 9600 bps; maximum distance is greater for lower data rates and less for higher data rates
Operation	Point-to-point, full- or half-duplex
RTS/CTS Delay	0, 6.6, or 53 ms (user-selectable for each port)
CD Signal	Constantly ON or controlled by RTS (user-selectable for each port)
RI (Ring Indicator) Signal	Constantly ON
Indicators	(6) Top-mounted LEDs: (2) each for TD, RTS, and CD

Connectors	ME240A-F: (2) DB25 female; ME240A-M: (2) DB25 male
Leads Supported	Pins 1 through 8, 15, 17, 20, 22, and 24 (PGND, TD, RD, RTS, CTS, DSR, SGND, RLSA [CD], TSETC [TC], RSETC [RC], DTR, RI, and TSETT [EXTC] respectively)
Grounding	Protective Ground (Pin 1) and Signal Ground (Pin 7) jumpered together on either Port 1 or Port 2 (user-selectable)
Power	Derived from the positive voltage on Pins 2, 4, and 20 of the RS-232 interface
Altitude Tolerance	Up to 10,000 feet (3048 meters)
Temperature	
Tolerance	Operating: 32 to 114°F (0 to 45° C); Storage: -40 to 176° F (-40 to 80° C)
Humidity	
Tolerance	Up to 95% noncondensing
Size	5.3"H x 2"W x 1.2"D (13.5 x 5.1 x 3 cm)
Weight	0.2 lb. (0.1 kg; approx. 3 oz./90 g)

2. Introduction

2.1 Description

The SME–NPR (LED) is an ultracompact, non-powered, synchronous-data modem eliminator used in point-to-point data transmission. It enables two RS-232 devices (terminals, PCs, workstations, mainframes, etc.) to exchange synchronous data at any of a variety of data rates from 1200 to 38,400 bps.

Under ideal conditions, including the use of high-grade cables and the presence of the full ± 12 VDC RS-232 voltage on Pins 2, 4, and 20, the SME–NPR (LED) supports a transmission distance of 600 feet (183 m)—up to 300 ft. (91.4 m) on either side of the unit—at 9600 bps. (Lower-quality cables or lower voltages will limit the attainable transmission distance; also, the maximum distance is inversely proportional to the data rate—the faster you transmit data, the shorter the distance you can send it, and the slower you send data, the greater the distance you can send it.)

2.2 Features and Benefits

REGENERATES THE CONTROL AND CLOCKING SIGNALS BETWEEN TWO SYNCHRONOUS DEVICES.

By doing this, the SME-NPR (LED) can transmit and receive sync data across long distances in your in-house network (point-to-point applications only). It will propel your sync data farther than most synchronous modem eliminators on today's market. You can place two RS-232 DTEs where you need them to be; you aren't limited by the average modem eliminator's transmission-distance restrictions. This means easier network installations and configurations, and better use of your network hardware.

USE TWO SETS OF INTERNAL JUMPERS TO CONFIGURE THIS MODEM ELIMINATOR TO SIMULATE A DIALUP OR LEASED TELEPHONE LINE.

Use the SME-NPR (LED) in your sync data network for just about any application you have—run-of-the-mill or vendor-specific. The SME-NPR (LED) lets you select from three RTS/CTS delay options, and you can set the Carrier Detect to either “Constantly ON” or “Controlled by RTS.”

SIX LEDs INDICATE THE STATUS OF TD, RTS, CD LEADS.

These show transitions in the logic states for Transmit Data (TD), Request to Send (RTS), and Carrier Detect (CD) on each port. You can see at a glance what is happening with the data signal from the transmitting DTE, and you'll know if your sync terminals and mainframe are properly interacting with each other by monitoring the RTS and CD activity. You can troubleshoot problems fast, and that means less network downtime.

GET THE CLOCK FROM THE INTERNAL CRYSTAL-CONTROLLED TIMING ELEMENT, OR FROM EITHER ATTACHED DTE.

You can let the SME-NPR (LED) generate the clock signal by setting the SME-NPR (LED)'s Rate Select jumper to one of the defined data-rate options ("internal clocking"—see below). Or you can set the jumper to "external clock" to use the clock signal provided by either DTE (*not* both).

SIX AVAILABLE INTERNAL DATA RATES.

Set the SME-NPR (LED)'s Rate Select jumper to choose the speed best suited to your application: 1200, 2400, 4800, 9600, 19,200, or 38,400 bps. If you upgrade your system's data rate later, or need to send a one-time transmission at a different speed, just change this jumper—the SME-NPR (LED) won't hold you back.

SME-NPR (LED)

DERIVES POWER FROM THE RS-232 INTERFACE—NO POWER SUPPLY NEEDED.

The SME-NPR is a “nonpowered” device: You won’t find a built-in power supply in this unit, nor does it need an external power device. It doesn’t even need batteries. This modem eliminator is engineered to operate on a small amount of power taken from the connected DTEs across the RS-232 interface.

IT’S THE SMALLEST SYNCHRONOUS MODEM ELIMINATOR ON THE U.S. MARKET.

You can connect it in-line between two data cables running between two DTEs, or attach it directly to a DTE’s serial port and connect the data cable to the other side.

3. Configuration

Before you install the SME-NPR (LED), configure it for the requirements of your point-to-point synchronous system by setting up to five sets of jumpers inside the unit. (Please be aware that this modem eliminator will not work in a multipoint environment.)

To change the settings of the SME-NPR (LED)'s internal jumpers, take these steps:

1. Loosen the hex nuts on the unit's DB25 connectors.
2. Open the case: insert a small screwdriver in the plastic shell slot on one side of the unit's chassis and *gently* pry apart the two portions of the case; repeat this step on the other side of the unit.
3. Lift, remove, and reposition the individual jumpers on the unit's circuit board as necessary; refer to Table 3-1 on the next page and either Figure 3-1 on page 13 (for the ME240A-F) or Figure 3-2 on page 14 (for the ME240A-M). If you find the jumpers too difficult to handle with your fingers, use needle-nosed pliers or a pair of tweezers.
4. When you are finished, reclose the unit's case and retighten the hex nuts on its connectors.

Table 3-1. Jumper Settings

Strap Identity	Function	Possible Positions	Factory Setting
Rate Select	Determines the rate at which data is transmitted	1.2 Kbps 2.4 Kbps 4.8 Kbps 9.6 Kbps 19.2 Kbps 38.4 Kbps Ext. Clock	9.6 Kbps
Delay 1	Determines how much time elapses between when Port 1 receives RTS and when it responds by raising CTS	0 msec 6.6 msec 53 msec	6.6 msec
Delay 2	Determines how much time elapses between when Port 2 receives RTS and when it responds by raising CTS	0 msec 6.6 msec 53 msec	6.6 msec
Carrier (Port 1)	Determines whether Port 1's CD signal is constantly ON (high) or controlled by Port 2's RTS signal.	ON CTRL'D	ON
Carrier (Port 2)	Determines whether Port 2's CD signal is constantly ON (high) or controlled by Port 1's RTS signal.	ON CTRL'D	ON
Ground	Connects protective ground from Port 1 or 2 to the unit's signal ground	#1 PG=SG #2 PG=SG	#1 PG=SG

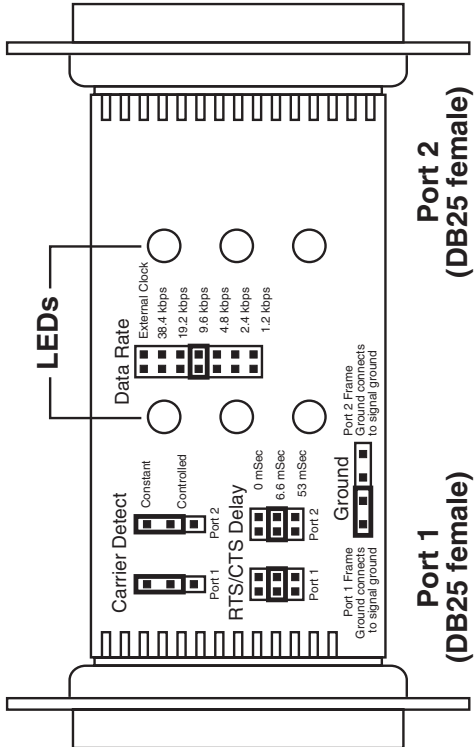

Figure 3-1. Jumper locations on the ME240A-F's circuit board.

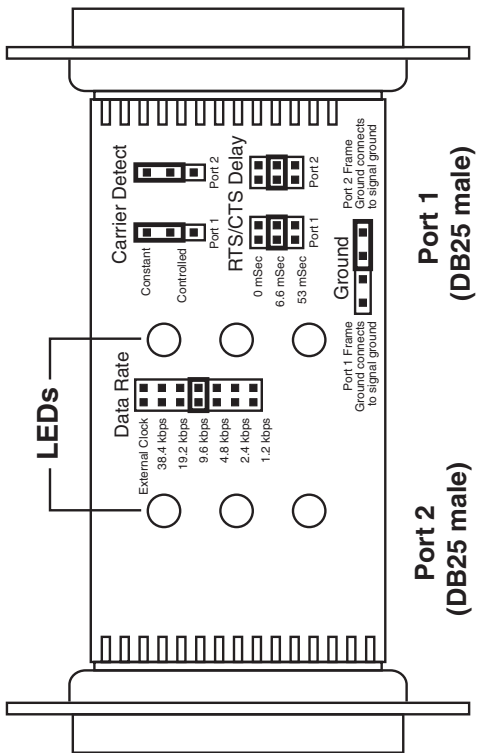

Figure 3-2. Jumper locations on the ME240A-M's circuit board.

4. Installation and Operation

To install your SME-NPR (LED) between the RS-232 cables coming from two DTEs, simply attach one cable to Port 1 and the other to Port 2; if there are sufficiently strong TD, RTS, and/or DTR signals on either or both lines, the unit will operate whenever either DTE sends data across the link.

To install your SME-NPR (LED) between a DTE's RS-232 port and an RS-232 cable coming from another DTE, simply plug the unit into the port—screwing the screwlocks in firmly—then attach the cable to the other side of the unit. Exercise caution; if the cable or its connector is very heavy, it could bend and damage the SME-NPR (LED) and/or the DTE's serial port. Unless there is some sort of hardware problem (missing or bent pins, etc.), the unit will operate whenever the attached DTE sends data. The unit will also operate whenever the other DTE sends data, as long as there are sufficiently strong TD, RTS, and/or DTR signals on the line.

SME-NPR (LED)

The SME-NPR (LED) is not really designed to be installed between a DTE and a DCE or between two DCEs. If you need to do this, you will require cross-pinned cables; call Black Box for technical support.

5. Troubleshooting

5.1 Calling Black Box

If your SME-NPR (LED) seems to be malfunctioning, *do not attempt to alter or repair the unit*. Call Black Box Technical Support at (412) 746-5500; the problem might be solvable over the phone.

Before you call, make a record of the history of the problem. Your supplier will be able to provide more efficient and accurate assistance if you have a complete description, including:

- the nature and duration of the problem.
- when the problem occurs.
- the components (vehicle, devices, etc.) involved in the problem.
- any particular application that, when used, appears to create the problem or make it worse.

5.2 Shipping and Packaging

If you need to transport or ship your SME-NPR (LED):

- Carefully package the unit. We recommend that you use the original container.
- If the shipping is return- or repair-related, contact Black Box to get a Return Materials Authorization (RMA) number.

A. Block Diagram

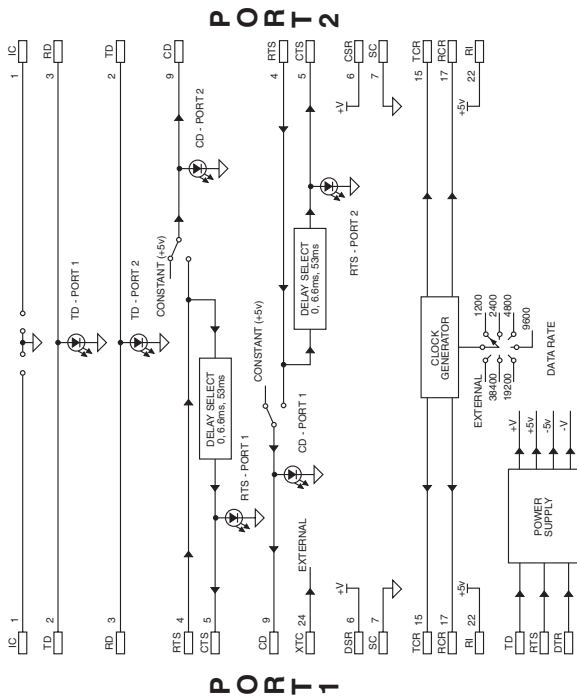

Figure A-1. System Block Diagram.



© Copyright 1998. Black Box Corporation. All rights reserved.

1000 Park Drive • Lawrence, PA 15055-1018 • (412) 746-5500 • Fax (412) 746-0746