

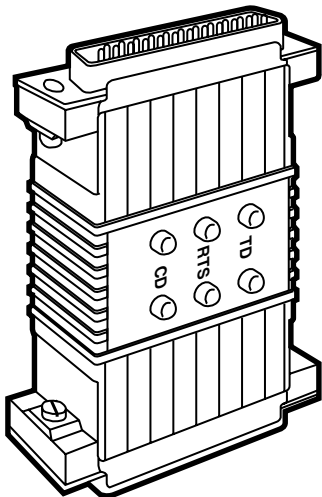

High Speed Sync Modem Eliminator—Nonpowered (SME-NPR)



CUSTOMER SUPPORT INFORMATION

Order **toll-free** in the U.S.: Call **877-877-BBOX** (outside U.S. call **724-746-5500**)

FREE technical support 24 hours a day, 7 days a week: Call **724-746-5500** or fax **724-746-0746**

Mailing address: **Black Box Corporation**, 1000 Park Drive, Lawrence, PA 15055-1018

Web site: www.blackbox.com • E-mail: info@blackbox.com

**FEDERAL COMMUNICATIONS COMMISSION
AND
CANADIAN DEPARTMENT OF COMMUNICATIONS
RADIO FREQUENCY INTERFERENCE STATEMENTS**

This equipment generates, uses, and can radiate radio frequency energy and if not installed and used properly, that is, in strict accordance with the manufacturer's instructions, may cause interference to radio communication. It has been tested and found to comply with the limits for a Class A computing device in accordance with the specifications in Subpart J of Part 15 of FCC rules, which are designed to provide reasonable protection against such interference when the equipment is operated in a commercial environment. Operation of this equipment in a residential area is likely to cause interference, in which case the user at his own expense will be required to take whatever measures may be necessary to correct the interference.

Changes or modifications not expressly approved by the party responsible for compliance could void the user's authority to operate the equipment.

This digital apparatus does not exceed the Class A limits for radio noise emission from digital apparatus set out in the Radio Interference Regulation of the Canadian Department of Communications.

Le présent appareil numérique n'émet pas de bruits radioélectriques dépassant les limites applicables aux appareils numériques de classe A prescrites dans le Règlement sur le brouillage radioélectrique publié par le ministère des Communications du Canada.

NORMAS OFICIALES MEXICANAS (NOM)

ELECTRICAL SAFETY STATEMENT

INSTRUCCIONES DE SEGURIDAD

1. Todas las instrucciones de seguridad y operación deberán ser leídas antes de que el aparato eléctrico sea operado.
2. Las instrucciones de seguridad y operación deberán ser guardadas para referencia futura.
3. Todas las advertencias en el aparato eléctrico y en sus instrucciones de operación deben ser respetadas.
4. Todas las instrucciones de operación y uso deben ser seguidas.
5. El aparato eléctrico no deberá ser usado cerca del agua—por ejemplo, cerca de la tina de baño, lavabo, sótano mojado o cerca de una alberca, etc..
6. El aparato eléctrico debe ser usado únicamente con carritos o pedestales que sean recomendados por el fabricante.
7. El aparato eléctrico debe ser montado a la pared o al techo sólo como sea recomendado por el fabricante.
8. Servicio—El usuario no debe intentar dar servicio al equipo eléctrico más allá a lo descrito en las instrucciones de operación. Todo otro servicio deberá ser referido a personal de servicio calificado.
9. El aparato eléctrico debe ser situado de tal manera que su posición no interfiera su uso. La colocación del aparato eléctrico sobre una cama, sofá, alfombra o superficie similar puede bloquea la ventilación, no se debe colocar en libreros o gabinetes que impidan el flujo de aire por los orificios de ventilación.
10. El equipo eléctrico deber ser situado fuera del alcance de fuentes de

calor como radiadores, registros de calor, estufas u otros aparatos (incluyendo amplificadores) que producen calor.

11. El aparato eléctrico deberá ser conectado a una fuente de poder sólo del tipo descrito en el instructivo de operación, o como se indique en el aparato.
12. Precaución debe ser tomada de tal manera que la tierra física y la polarización del equipo no sea eliminada.
13. Los cables de la fuente de poder deben ser guiados de tal manera que no sean pisados ni pellizcados por objetos colocados sobre o contra ellos, poniendo particular atención a los contactos y receptáculos donde salen del aparato.
14. El equipo eléctrico debe ser limpiado únicamente de acuerdo a las recomendaciones del fabricante.
15. En caso de existir, una antena externa deberá ser localizada lejos de las líneas de energía.
16. El cable de corriente deberá ser desconectado del cuando el equipo no sea usado por un largo periodo de tiempo.
17. Cuidado debe ser tomado de tal manera que objetos líquidos no sean derramados sobre la cubierta u orificios de ventilación.
18. Servicio por personal calificado deberá ser provisto cuando:
 - A: El cable de poder o el contacto ha sido dañado; u
 - B: Objetos han caído o líquido ha sido derramado dentro del aparato; o
 - C: El aparato ha sido expuesto a la lluvia; o
 - D: El aparato parece no operar normalmente o muestra un cambio en su desempeño; o
 - E: El aparato ha sido tirado o su cubierta ha sido dañada.

TRADEMARKS

All applied-for and registered trademarks are the property of their respective owners.

Contents

Chapter	Page
1. Specifications	8
2. General Information	10
2.1 Features	10
2.2 Description.....	11
3. Configuration	12
3.1 Data Rate	14
3.2 Carrier Detect	14
3.3 RTS/CTS Delay	14
3.4 Ground.....	15
4. Installation	16
5. Operation.....	17
LED Status Indicators.....	17
Appendix: Block Diagram.....	19

1. Specifications

Data Rates—Strap-selectable for 16, 32, 64, 128, 256, or 512 kbps

Clocking—Strap-selectable for internal or external clock

Grounding—Protective ground (pin 1) may be strapped to signal ground (pin 7)

Range—75 feet (22.8 m) on either side, for a total of 150 feet (45.6 m), at 64 kbps; range extends linearly for lower bit rates and decreases for higher bit rates

Functional—Emulates half- or full-duplex, dial-up or dedicated line

RTS/CTS Delay—Selectable per port: 0 ms or 6.6 ms

DCD—Selectable per port as continuous or RTS controlled

Ring Indicator—Constantly ON

Interface—EIA RS-232C/CCITT V.24

Connectors—*ME241A-M*: (2) DB25 male;
ME241A-F: (2) DB25 female

Power Supply—None required

Maximum Altitude—10,000 feet (3048 m)

Humidity—Up to 95% non-condensing

Size—5.3"H x 2"W x 1.2"D (13.4 x 5.1 x 3.1 cm)

2. General Information

2.1 Features

- Synchronous data rates to 512 kbps
- Cable runs to 75 feet (22.8 m) on each side of device
- Constant or RTS controlled carrier selections
- RTS-CTS delay options of 0 ms or 6.6 ms
- DB25 connector on each end
- Half- or full-duplex
- Internal or external clocking
- No external power required
- LEDs monitor data and control signals

2.2 Description

The High Speed Sync Modem Eliminator—Nonpowered (SME-NPR), part number ME241A, allows two synchronous RS-232 DTE (host) devices to communicate with each other without the need for expensive synchronous modems. Supporting selectable data rates of 16, 32, 64, 128, 256, and 512 kbps, the SME-NPR needs no AC power or batteries for operation. The SME-NPR provides internal or external clock options and operates half or full duplex. To emulate dial-up or dedicated service, the delay between RTS and CTS can be set to either 0 mS or 6.6 mS. The carrier can be configured either as “constantly on” or “controlled by RTS.”

Measuring only 5.3"H x 2"W x 1.2"D (13.4 x 5.1 x 3.1 cm), the SME-NPR is equipped with a DB25 connector on each end. Cable runs up to 75 feet (22.8 m) on either side of the device—50 feet (45.6 m) total—are possible at the optimum data rate of 64 kbps. Tri-state LED indicators monitor receive data, request to send, and data carrier detect on each side of the device.

3. Configuration

The SME-NPR is equipped with four strapping options that allow configuration to a wide range of applications. To gain access to the internal straps, loosen the hex nuts on the DB25 connectors and pry open the case between the plastic shell ears. **Figure 3-1** shows the location of each strapping option.

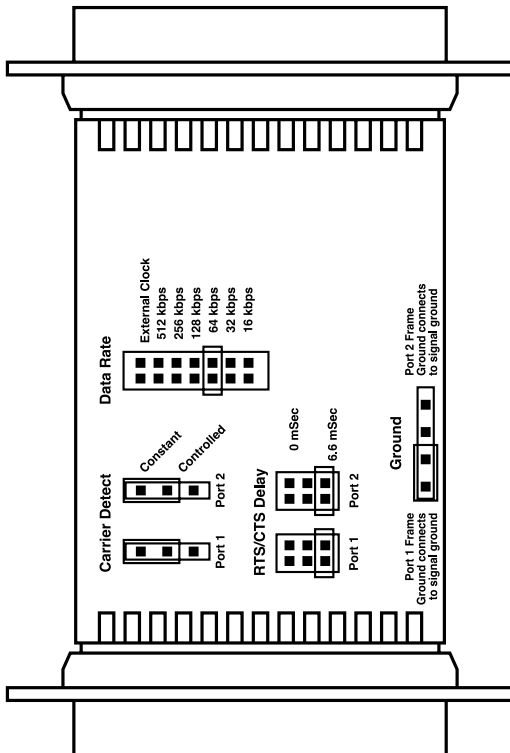

Figure 3-1. Strap Settings for the SME-NPR.

3.1 Data Rate

The data-rate strap controls the rate at which data is transmitted. Adjust the strap to select one of the following options: 16, 32, 64, 128, 256, or 512 kbps, or external clocking. If “external clocking” is selected, the SME-NPR will automatically match the clocking between your two synchronous devices. The default setting is 64 kbps.

3.2 Carrier Detect

The carrier detect straps allow you to determine whether the carrier is “constantly on” or “controlled by RTS.” By adjusting the strap, you may operate in switched-carrier, multipoint, and hardware-handshaking applications. Port 1 and port 2 may be configured separately. The default setting is ON for both ports.

3.3 RTS/CTS Delay

The RTS/CTS delay straps determine the amount of delay between the time the SME-NPR “sees” RTS and when it sends CTS. To emulate either dial-up or leased-line modems, you can set this strap at either no delay or 6.6 ms. Port 1 and port 2 may be configured separately. The default setting is 6.6 ms for both ports.

3.4 Ground

The ground strap setting connects the protective ground from port 1 or 2 to the SME-NPR's signal ground. The default setting is port 1.

4. Installation

The SME-NPR is very simple to install.

1. Configure according to the instructions listed in **Chapter 3**.
2. Turn off the computer or device to which the SME-NPR is to be connected.
3. Plug the DB25 connectors directly into the serial ports of your RS-232 devices. If you wish to extend the distance, you may add a cable not to exceed 75 feet (22.8 m) on each side.

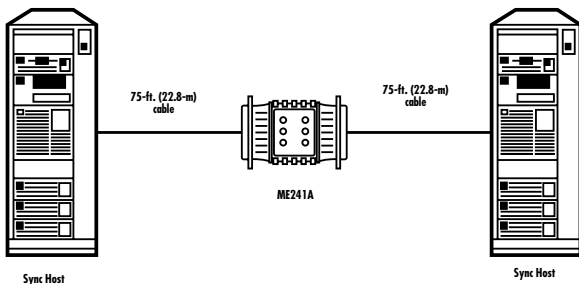

Figure 4-1. Installing the SME-NPR.

5. Operation

Once you have configured the SME-NPR properly (see **Chapter 3**) and plugged it into your equipment, you are ready to operate the unit. After the SME-NPR is properly installed, it should operate transparently—as if it were a standard cable connection. Operating power is derived from the RS-232 data and control signals; there is no “ON/OFF” switch.

LED Status Indicators

The SME-NPR features six front-panel status LEDs that indicate the condition of the modem eliminator and the communication link. **Figure 5-1** shows the location of each of these LEDs. Following the diagram is a description of each LED’s function.

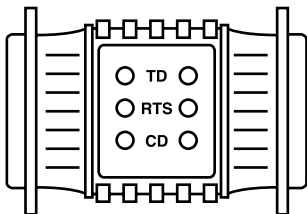

Figure 5-1. Location of the LEDs on the Front Panel.

- TD and RTS indicators blink with data activity.
- CD lights for an incoming signal on the line side and the resulting output signal on the RS-232.

Appendix: Block Diagram

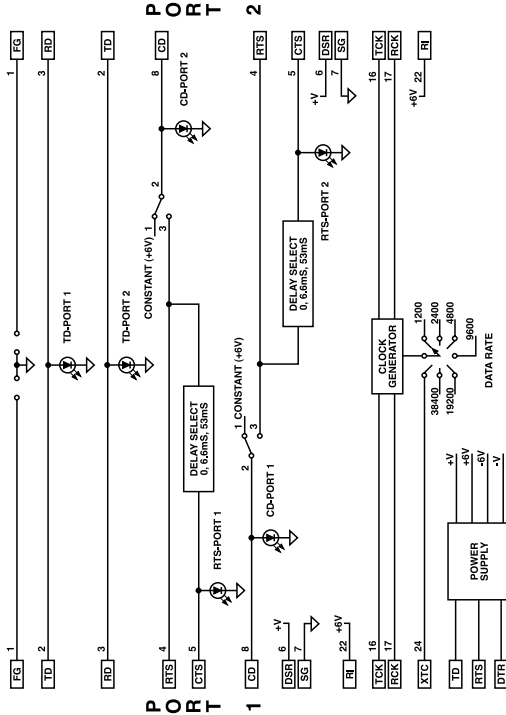

Figure A-1. Block Diagram for the SME-NPR.



© Copyright 1995. Black Box Corporation. All rights reserved.

1000 Park Drive • Lawrence, PA 15055-1018 • 724-746-5500 • Fax 724-746-0746