

### SPECIFICATIONS:

**Protocol:** Synchronous, full duplex.

**Speed:** 1200 to 19,200 bps

**Transmission Line:** Two unconditioned twisted pair 19-26 AWG.

**Serial Interface:** EIA RS-232, CCITT V.24

**Isolation:** Minimum 1500 V RMS via custom transformers.

**Surge Protection:** 600 W power dissipation at 1 ms and response time of 1 picosecond.

**Control Signals:** CTS turns on 7 or 53 ms (switch-selectable) after the terminal raises RTS; DSR and DCD are constantly on.

**Connectors:** (1) DB25 male or female; (1) RJ-11 female connector.

**Power:** No power required; uses 6 VDC power from EIA data and control signals: Pins 2,4,9 and 20

DATA RATE (bps)	Distance Table in miles (km)		
	WIRE GAUGE		
	19 AWG	24 AWG	26 AWG
19,200	7.5 mi (12 km)	3.5 mi (5.6 km)	2.5 mi (4 km)
9,600	10 mi (16.1 km)	3.5 mi (5.6 km)	2.5 mi (4 km)
4,800	10 mi (16.1 km)	7 mi (11.3 km)	4 mi (6.4 km)
2,400	10 mi (16.1 km)	8.5 mi (13.7 km)	5 mi (8.1 km)
1,200	11 mi (17.7 km)	8.5 mi (13.7 km)	6 mi (9.7 km)

# ME754A-M/F (also with optional Surge Protection MSP/FSP)

### DESCRIPTION:

The Mini-Driver 4W-S-CL is a miniature, synchronous short-range modem that uses the latest in VLSI technology to combine high-quality data transmission with compact size. The Mini Driver does not need any AC power or batteries to operate, and communicates up to 11 miles (17.7 km) in point-to-point environments. For maximum flexibility, the Mini Driver supports three clocking options: internal, external or receive loopback.

Supporting full-duplex transmission over two twisted pairs, the Mini Driver accommodates seven switch selectable data rates from 1200 to 19,200 bps. The Mini Driver's custom VLSI chip uses a separate filter for each data rate, rather than a single "compromise" filter. Transformer isolation allows the Mini Driver to operate between buildings without data disruption because of ground potential differences.

The -MSP and -FSP models are surge-protected versions of the Mini Driver, incorporating silicon avalanche diodes that provide 600 watts of protection per wire.

### CONFIGURATION:

The Mini Driver has six configuration switches that let you select clocking method, RTS/CTS delay and data rates.

#### Switch Setting:

All possible settings for the Mini Driver's configuration switches are presented in the summary table and descriptions below.

**Switches 1 and 2: Transmit Clock** are used together to specify the clocking method. The Mini Driver can provide an internal clock (Pin 15), receive an external clock (from pin 24), or loop back a received clock.

Switch 1	Switch 2	Setting:
ON	ON	External Clock
ON	OFF	External Clock
OFF	ON	Internal Clock (default)
OFF	OFF	Receive Loopback

**Switch 3: RTS/CTS Delay** After request to send (RTS) is raised by the host terminal, the Mini Driver raises CTS after a slight delay in order to give the remote terminal time to receive an incoming signal. Depending on the type of environment, either 7 msec. or 53 msec can be selected.

Switch 3	Setting:
ON	7 msec. (default)
OFF	53 msec.

**Switch 4 through 6: Data Rate**

Switch 4	Switch 5	Switch 6	Setting:
ON	ON	ON	1200 bps
ON	ON	OFF	2400 bps
ON	OFF	ON	4800 bps
OFF	ON	ON	7200 bps
ON	OFF	OFF	9600 bps
OFF	ON	OFF	14400 bps
OFF	OFF	ON	19200 bps
OFF	OFF	OFF	19200 bps

Continued on next page:

### Installation:

Once the Mini Driver is properly configured, it is ready to connect to your system. The Mini Driver supports data-only communication between two RS-232 devices at a distance to 11 miles and data rates to 19.2 Kbps. There are two essential requirements for installing the Mini Driver:

1. These units work in pairs. Therefore, you must have one Mini Driver at each end of a two twisted-pair interface.
2. To function properly, the Mini Driver needs two twisted pairs of metallic wire. These pairs must be unconditioned, dry, metallic wire, between 19 and 26 AWG (the higher-number gauges may limit distance somewhat). Standard dial-up telephone circuits, or leased circuits that run through signal-equalization equipment, are not acceptable.

The RJ-11 connector on the Mini Driver's twisted-pair interface are pre-wired for a standard telco wiring environment. The signal/pin relationships are shown below. When connecting two Mini Drivers, you will need to use a "crossover cable". The figure below shows how a crossover cable should be constructed for an environment where both Mini Drivers use a 6-wire RJ-11 connector.

<u>PIN</u>	<u>SIGNAL</u>
1	GND
2	RCV-
3	XMT+
4	XMT-
5	RCV+
6	GND

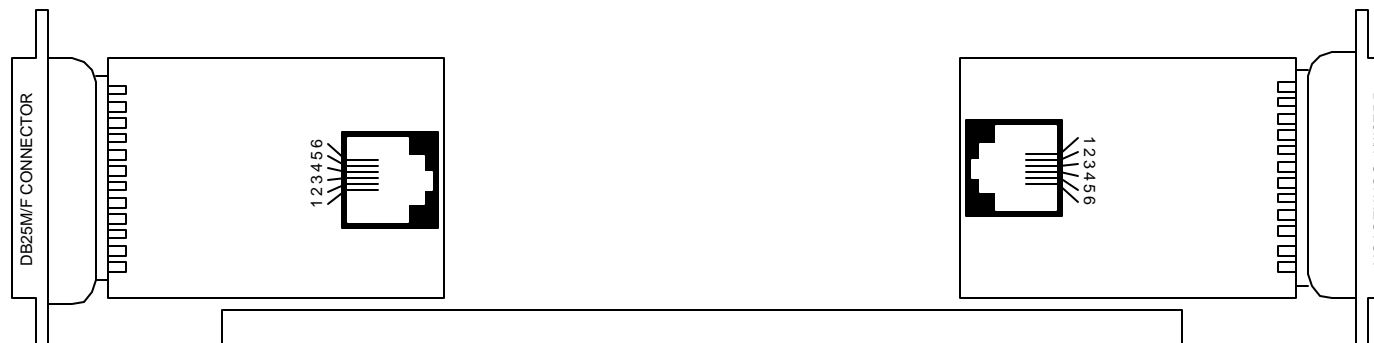
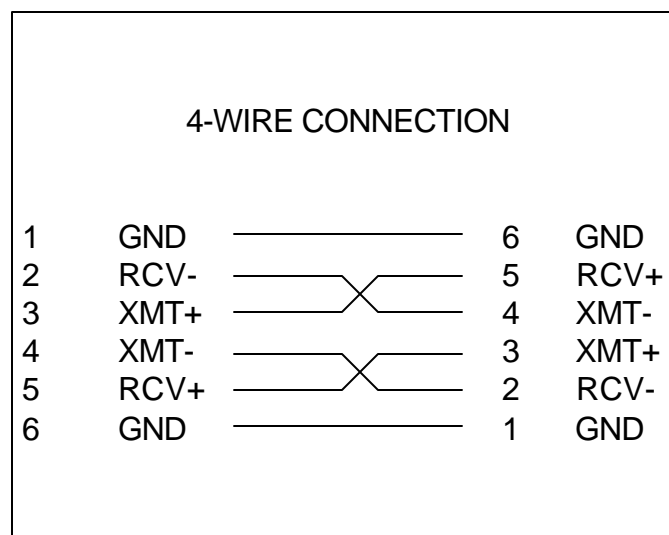

*If there is a shield around the telephone cable, it may be connected to "G" on the terminal block. We recommend connecting the shield at the computer end only to avoid ground loops. A ground wire is not necessary to properly operate the Driver.*