



© Copyright 2000. Black Box Corporation. All rights reserved.

1000 Park Drive • Lawrence, PA 15055-1018 • 724-746-5500 • Fax 724-746-0746

**FEDERAL COMMUNICATIONS COMMISSION
AND
INDUSTRY CANADA
RADIO FREQUENCY INTERFERENCE STATEMENTS**

This equipment generates, uses, and can radiate radio frequency energy and if not installed and used properly, that is, in strict accordance with the manufacturer's instructions, may cause interference to radio communication. It has been tested and found to comply with the limits for a Class A computing device in accordance with the specifications in Subpart J of Part 15 of FCC rules, which are designed to provide reasonable protection against such interference when the equipment is operated in a commercial environment. Operation of this equipment in a residential area is likely to cause interference, in which case the user at his own expense will be required to take whatever measures may be necessary to correct the interference.

Changes or modifications not expressly approved by the party responsible for compliance could void the user's authority to operate the equipment.

This digital apparatus does not exceed the Class A limits for radio noise emission from digital apparatus set out in the Radio Interference Regulation of Industry Canada.

Le présent appareil numérique n'émet pas de bruits radioélectriques dépassant les limites applicables aux appareils numériques de classe A prescrites dans le Règlement sur le brouillage radioélectrique publié par Industrie Canada.

NORMAS OFICIALES MEXICANAS (NOM) ELECTRICAL SAFETY STATEMENT

INSTRUCCIONES DE SEGURIDAD

1. Todas las instrucciones de seguridad y operación deberán ser leídas antes de que el aparato eléctrico sea operado.
2. Las instrucciones de seguridad y operación deberán ser guardadas para referencia futura.
3. Todas las advertencias en el aparato eléctrico y en sus instrucciones de operación deben ser respetadas.
4. Todas las instrucciones de operación y uso deben ser seguidas.
5. El aparato eléctrico no deberá ser usado cerca del agua—por ejemplo, cerca de la tina de baño, lavabo, sótano mojado o cerca de una alberca, etc..
6. El aparato eléctrico debe ser usado únicamente con carritos o pedestales que sean recomendados por el fabricante.
7. El aparato eléctrico debe ser montado a la pared o al techo sólo como sea recomendado por el fabricante.
8. Servicio—El usuario no debe intentar dar servicio al equipo eléctrico más allá a lo descrito en las instrucciones de operación. Todo otro servicio deberá ser referido a personal de servicio calificado.
9. El aparato eléctrico debe ser situado de tal manera que su posición no interfiera su uso. La colocación del aparato eléctrico sobre una cama, sofá, alfombra o superficie similar puede bloquea la ventilación, no se debe colocar en libreros o gabinetes que impidan el flujo de aire por los orificios de ventilación.

10. El equipo eléctrico deber ser situado fuera del alcance de fuentes de calor como radiadores, registros de calor, estufas u otros aparatos (incluyendo amplificadores) que producen calor.
11. El aparato eléctrico deberá ser conectado a una fuente de poder sólo del tipo descrito en el instructivo de operación, o como se indique en el aparato.
12. Precaución debe ser tomada de tal manera que la tierra fisica y la polarización del equipo no sea eliminada.
13. Los cables de la fuente de poder deben ser guiados de tal manera que no sean pisados ni pellizcados por objetos colocados sobre o contra ellos, poniendo particular atención a los contactos y receptáculos donde salen del aparato.
14. El equipo eléctrico debe ser limpiado únicamente de acuerdo a las recomendaciones del fabricante.
15. En caso de existir, una antena externa deberá ser localizada lejos de las líneas de energia.
16. El cable de corriente deberá ser desconectado del cuando el equipo no sea usado por un largo periodo de tiempo.
17. Cuidado debe ser tomado de tal manera que objetos liquidos no sean derramados sobre la cubierta u orificios de ventilación.
18. Servicio por personal calificado deberá ser provisto cuando:
 - A: El cable de poder o el contacto ha sido dañado; u
 - B: Objetos han caído o líquido ha sido derramado dentro del aparato; o
 - C: El aparato ha sido expuesto a la lluvia; o
 - D: El aparato parece no operar normalmente o muestra un cambio en su desempeño; o
 - E: El aparato ha sido tirado o su cubierta ha sido dañada.

TRADEMARKS USED IN THIS MANUAL

Any trademarks mentioned in this manual are acknowledged to be the property of the trademark owners.

1. Specifications

Transmission —

Data Rate (bps)	AWG (mm)	
	24 (0.5)	26 (0.4)
	Distance in miles	
115,200	0.8	0.7
57,600	1.2	0.8
38,400	1.3	0.9
19,200	1.5	1.2
9600	2	1.5
4800	2.6	2
2400	4	3
1200	4.8	4

NOTE: The above specifications are valid for 24- or 26-AWG unshielded twisted-pair telephone cable insulated by polyethylene with a mutual capacitance of 0.083 pf/mile. Shielded twisted-pair cable will reduce the distance to one-third of the table value, due to the additional capacitance contributed by the cable's shielding. Actual distances may vary depending on your specific operating equipment and the cable you use.

Protocol — Asynchronous

Operation — 4-wire, full duplex, point-to-point

Line Interface — Balanced current loop; Receive lines are protected through optical isolators rated at 1500 volts

Equipment Interface — EIA-232/CCITT V.24 interface with a hardware handshake (selected through use of an external switch). Data Carrier Detect (DCD) true (high) indicates operating short-haul modem at the remote end of the loop. Interface is switch-selectable for DTE/DCE configuration (pins 2 and 3 reversed, pins 4 and 5 reversed with pin 8, pin 6 reversed with pin 20)

Connectors — (1) DB25 female, (1) 4-screw terminal block, (1) RJ-11 (6 positions, 6 contacts), (1) 4-position mini-DIN jack

Diagnostics — Loopbacks provided by a front-panel switch: Analog loopback on a 4-wire loop and digital loopback on equipment interface (EIA-232)

Status Indication — Two bi-color LEDs indicate the status of the transmitter and receiver. A green light indicates a “low” logic level (-3 to -15V) on the EIA-232 interface; a red light indicates a “high” logic level (+3 to +15V).

Operating Temperature — 32 to 112°F (0 to 50°C)

Humidity — 90% maximum, noncondensing

Enclosure — High-impact plastic

Power — Power is supplied by a wall-mounted power transformer. No more than 16 Vrms is present in unit.

Primary: 115 VAC $\pm 10\%$, 60 Hz, 5 watts (12 watts max.);
Primary: 230 VAC $\pm 10\%$, 50/60 Hz; Secondary: 17 VAC,
700 mA

Size — 1.3"H x 4"W x 4.2"D (3.3 x 10.7 x 11.3 cm)

Weight — 1.4 lb. (0.6 kg), standalone, including transformer

2. Introduction

The Short-Haul Modem Model B Async Plus (SHM-B Async) is an asynchronous full-duplex 4-wire line driver/receiver which allows two EIA-232 devices to communicate at distances of up to 4 miles and at data speeds of up to 115.2 kbps. In addition to the transmitter and receiver circuits, the SHM-B Async Plus includes EIA-232 control line interfaces, status monitor LEDs, and a loopback switch. The SHM-B is available as a standalone version (ME800A-Plus).

The SHM-B is designed to operate over a 4-wire metallic circuit. Optimum performance is obtained with twisted-pair cable (see specifications). Most types of twisted-pair cable may be used, often with little or no performance degradation.

The SHM-B Async is designed for maximum operator safety. There are no voltages greater than 12 VDC or 16 VAC present on the circuit board of the unit. The Receive lines are protected from potential ground differences through optical isolators rated at 1500 volts.

3. Installation

Installation involves three basic steps: four-wire connections; EIA-232 connection; switch settings.

3.1 Four-Wire Connections

Connect pairs of modems using the terminal block or RJ-11 connectors provided. Figure 1 shows the location of the terminal block and the RJ-11 jack.

a) **TERMINAL BLOCK:**

Refer to Figure 2 to make the proper connections between two SHM-B units using the terminal block.

NOTE: Transmit + (TX+) on one modem is wired to Receive + (RX+) on the other modem; Transmit - (TX-) is wired to Receive - (RX-).

1. Strip each of the four wires about $\frac{1}{8}$ ".
2. Loosen the screw terminals in the terminal block. Insert the wires into the terminal strip; tighten the screw terminals.

SHM-B PLUS ASYNC

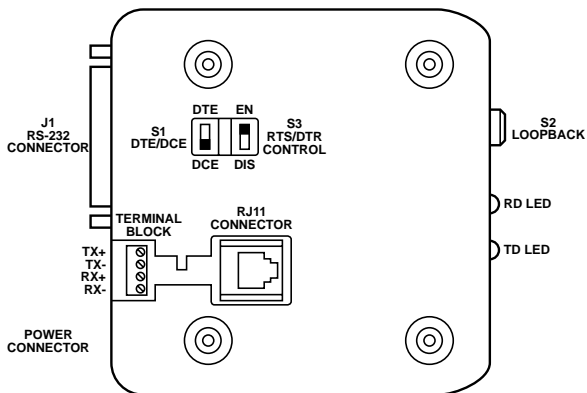

Figure 1. Bottom View.

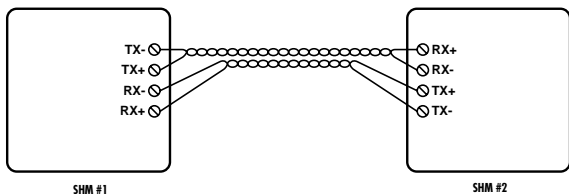

Figure 2. Wiring Diagram—Terminal Block.

b) RJ-11 JACK:

1. Connect pairs of modems using a crossover RJ-11 cable (refer to Figure 3). A crossover cable has the RJ-11 tabs on the same side of the cable.
2. Insert the RJ-11 cable into both local and remote modem's jack.

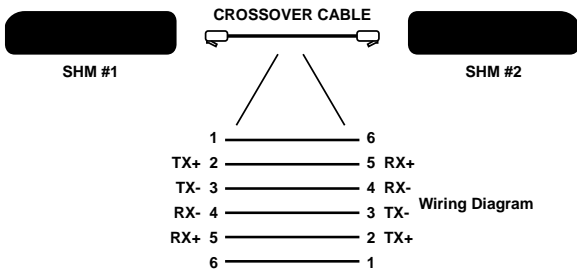

Figure 3. RJ-11 Jack.

3.2 EIA-232 Connection

Connect the SHM-B to your computer or terminal with a standard EIA-232 cable and DB25 connectors. Refer to your equipment's installation manual if you need information on the exact EIA-232 signals required for your equipment. Often, it is best to use only the Transmit Data (TD), Receive Data (RD), and ground lines if your equipment does not require the use of the control signals Request To Send (RTS), Clear To Send (CTS), Data Set Ready (DSR), etc. The SHM-B generates levels for the control signals if you need to use them. The table shows the pin connections at the SHM-B.

Table 1. EIA-232 Pin Connections on SHM-B

Pin Number	Signal Name
1	Protective Ground
2	Transmit Data/Receive Data (TD/RD)*
3	Receive Data/Transmit Data (RD/TD)*
4	Request to Send (RTS/DCD)*
5	Clear to Send (CTS/RTS)*
6	Data Set Ready (DSR/DTR)*
7	Signal Ground
8	Data Carrier Detect (DCD/RTS)*
20	Data Terminal Ready (DTR/DSR)*

*TD and RD, RTS and DCD, DSR and DTR can be reversed using the DTE/DCE switch S1 on the circuit board. See **Section 3.3** for details.

3.3 Switch Settings

DTE/DCE SWITCH

Refer to Figure 1 in this chapter. Switch S1 is used to reverse the TD, RD, and hardware flow control lines on the EIA-232 interface. This eliminates the need to swap these signals in your EIA-232 cables. If you connect the SHM-B to your equipment using a “straight-through” or “2:2” cable, then S1 must be set to the opposite of your device’s configuration. For example, if your device is configured as DTE, select DCE on S1. If you use a null modem, “2:3”, or “3:2” cable to connect the SHM-B to your equipment, then the setting for S1 will be identical to your equipment’s setting. Refer to your equipment’s manual for information concerning its DTE/DCE setting. Table 2 gives the EIA-232 pinning of the SHM-B with the DTE/DCE switch in the DCE position.

Table 2. Pinning with DTE/DCE switch in the DCE position.

PIN NUMBER	SIGNAL NAME	DIRECTION
1	Protective Ground	_____
2	Transmitted Data TD*	To DCE
3	Received Data RD*	From DCE
4	Request to Send (RTS)*	To DCE
5	Clear to Send (CTS)*	From DCE
6	Data Set Ready (DSR)*	From DCE
7	Signal Ground	_____
8	Data Carrier Detect (DCD)*	From DCE
20	Data Terminal Ready (DTR)*	To DCE

*Pins 2 and 3 (TD and RD), and hardware flow control can be reversed using the DTE/DCE switch, S1 on the circuit board.

NOTE

Configure each SHM-B independently. Your local and remote modems won't necessarily be configured the same.

3.4 Flow Control Switch

The SHM-B uses a clever, yet simple way to allow this unit to work with a broad line of equipment.

STANDARD EIA-232C HANDSHAKING (RTS/DTR CONTROL SWITCH S3 IN EN POSITION)

The individual SHM-B modems force their own DTR, RTS, CTS, and DSR control lines HIGH (>+3V) when:

- The twisted-pair wires are installed correctly.
- Power is applied to the modems.
- No computer devices are attached to the modems.

This forces DCD HIGH on the remote modem; thus, the remote modem knows to expect data. In this state, “all systems are go.” The only way this state changes is if your equipment overrides this condition. For example, if your equipment drops DTR to a NEGATIVE signal, your equipment’s DTR being low will override the SHM-B’s DTR, and DCD on the remote modem will go LOW.

Because DTR, DSR, RTS, and CTS are tied together internally, dropping any one of these four signals to a

negative state will also drop DCD on the remote side to a negative state. DCD will also go LOW if the remote SHM-B is powered down, or if the twisted-pair wire is broken.

X-ON/X-OFF MODE

(RTS/DTR CONTROL SWITCH [S3] IN DIS POSITION)

If X-ON/X-OFF characters are used for handshaking control, rather than hardware logic levels, move the RTS/DTR control switch to the DIS position.

Typically, units that use software X-ON/X-OFF flow control do not want RTS to affect DCD on the remote SHM-B. Moving the switch to the DIS position disables the RTS/DCD relationship. The only thing that will force DCD low with the switch in the DIS position is the absence of power on the remote SHM-B or a broken twisted-pair wire.

4. Operation

After completing the wiring and configuration procedure, connect the SHM-B to your equipment, then plug the wall transformer into its power source and into the SHM-B. Check the SHM-B operation at both ends of the loop by pressing the LOOPBACK switch, S2.

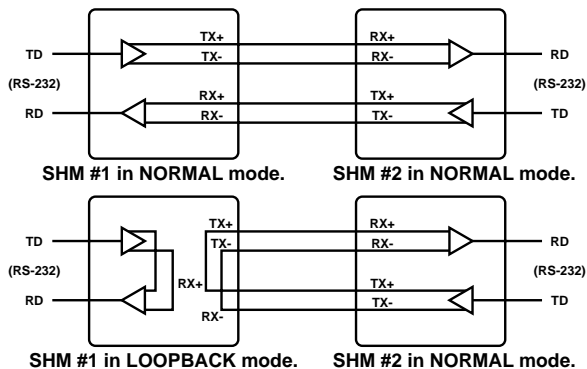

Figure 4. Activating the LOOPBACK switch.

When in loopback mode, the switch button indicator will appear white. If a CRT terminal is connected to the SHM-B, typing characters on the keyboard should result in the same characters appearing on the CRT screen. If no characters appear, check your EIA-232 connections and the setting of S1. See Figure 4 for an illustration of the loopback mode.

The TD and RD LEDs on the front panel of your SHM-B indicate the status of the SHM-B transmitter and receiver, respectively. Green indicates a LOW EIA-232 level and red indicates a HIGH EIA-232 level. The LEDs will modulate as data is transmitted and received by the SHM-B. Remember that these LEDs are monitoring the actual received and transmitted signals, *not* the TD and RD lines of the EIA-232 interface.

When the loopback test is completed, press the LOOPBACK switch again to return the SHM-B to normal mode. The switch button indicator should now be black. Data transmission between the two modems will now be possible.

If you experience problems communicating between the two SHM-Bs, use **Chapter 5** to help diagnose the problem.

5. Troubleshooting Guide

The following information will help you troubleshoot your installation if problems develop. If your particular situation isn't listed here, call Technical Support for assistance. Have ready a description of the problem with your installation, your DTE equipment make and models, your equipment's DTE/DCE configuration and flow control type (hardware or software), your EIA-232 cable pinouts, and what (if anything) you have already done to correct the situation.

SYMPTOM: LEDs do not light when power transformer is plugged into a wall outlet.

1. Is the power connection loose? Try moving or nudging the wall transformer.
2. If the LEDs still do not light, the SHM-B may be defective.

SYMPTOM: No data transfer in one or both directions (to, from, or to-and-from the SHM-B).

1. Monitor the TD LED on the sending-end modem while sending data. The light should flash red/green.

If not, check the DCE/DTE switch on that unit. Once you get a TD LED flashing on that unit, simultaneously the RD LED should flash on the other SHM-B unit. If not, go to step 2.

2. Inspect the wiring between the two modems. Have the wires been properly installed? Transmit + (TX+) on one modem must be wired to Receive + (RX+) on the other modem; also, Transmit - (TX-) must be wired to Receive - (RX-). Refer to Figure 2 during your inspection of the four-wire circuit.
3. Try a local test using the Loopback mode (see **Chapter 4**). If there is no transfer, check the setting of S1 and the wiring of your EIA-232 cable.
4. The EIA-232 control signals are at the wrong levels. Check the EIA-232 interface using a breakout box. Pins 4, 5, 6, 8, and 20 should all be HIGH to enable communication.
5. If pin 8 (Data Carrier Detect) is low, this indicates:
 - a defective transmission line or connection
 - a defective remote SHM-B

- remote SHM-B without power

SYMPTOM: TD and RD LEDs indicate data activity, but data communication doesn't exist.

1. Check the wiring of the EIA-232 port. Refer to **Section 3.2** for information.
2. Check the setting of S1. Refer to **Section 3.3** for information.

SYMPTOM: Transmitted and/or received data is full of errors (garbled data).

1. Check for reversal of polarity on the four-wire connection. Refer to **Section 3.1** and Figure 2.
2. Check communication settings (baud rate, parity, word size) on your computing equipment for consistency.
3. Wire the SHM-B units back-to-back, eliminating the twisted-pair; see if you still have errors.
 - If you do have errors, then test each SHM individually in the following way: loopback one SHM's Transmit-to-Receive by using two short

pieces of wire. Connect that SHM to a dumb terminal and key in characters; look for a good loopback. A good loopback verifies a SHM-B in proper working condition.

- If you don't have errors, you have verified a problem with the twisted-pair cable.

SYMPTOM: Occasional data errors.

1. The transmission distance/bps data rate capability rate may have been exceeded. Refer to **Chapter 1** for information about valid data transmission distances and bps rates.
2. There is a poor quality loop (four-wire circuit). Try using a different four-wire circuit, or rewire the existing circuit.
3. Check the path of your four-wire circuit for potential sources of interference (fluorescent lighting, electrical motors, etc.). Such sources of electrical “noise” can provide an environment in which unwanted signals are induced onto your four-wire circuit. Also, check to see if an adjacent four-wire cable carrying a separate data stream is creating

“crosstalk.” It may be that the data sign is jumping from the adjacent cable onto the four-wire circuit between the two SHM-B modems (another type of induced signal).

- While you are checking your cable for sources of noise and crosstalk, check the cable for irregularities in the shield. Also, reconsider the cable’s ratings for attenuation, capacitance, and impedance. You may need to install a higher-quality cable for your particular installation.
- Your AC power source may be the culprit. Check your AC power at the wall socket and confirm that it is within the range given in **Chapter 1**.

SYMPTOM: TD or RD indicator is steadily on red with no data attempting to pass (no DTEs attached).

Check for reversal of polarity on the four-wire connection.