

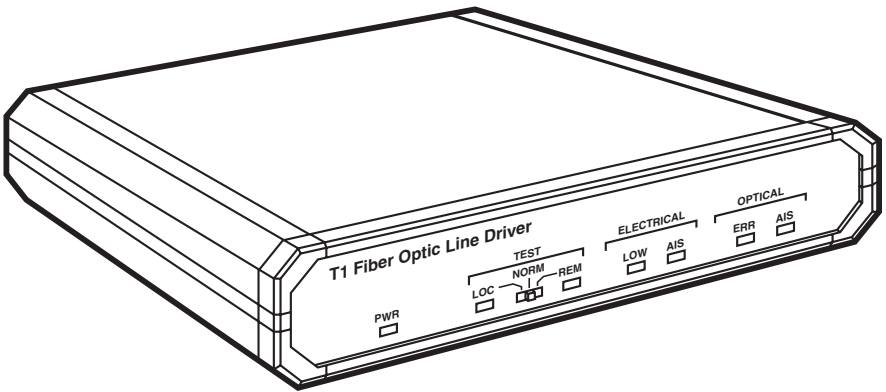

MT610A-ST	MT611A-ST
MT610A-SM	MT611A-SM
MT610AE-ST	MT611AE-ST
MT610AE-SM	MT611AE-SM
	MT613AE-FC
	MT613A-ST-D48

T1/E1 Fiberoptic Line Driver (T1/E1 FOLD)



**CUSTOMER
SUPPORT
INFORMATION**

Order toll-free in the U.S. 24 hours, 7 A.M. Monday to midnight Friday: **877-877-BBOX**
FREE technical support, 24 hours a day, 7 days a week: Call **724-746-5500** or fax **724-746-0746**
Mail order: **Black Box Corporation**, 1000 Park Drive, Lawrence, PA 15055-1018
Web site: www.blackbox.com • E-mail: info@blackbox.com

**FEDERAL COMMUNICATIONS COMMISSION
AND
INDUSTRY CANADA
RADIO FREQUENCY INTERFERENCE STATEMENTS**

This equipment generates, uses, and can radiate radio frequency energy and if not installed and used properly, that is, in strict accordance with the manufacturer's instructions, may cause interference to radio communication. It has been tested and found to comply with the limits for a Class A computing device in accordance with the specifications in Subpart J of Part 15 of FCC rules, which are designed to provide reasonable protection against such interference when the equipment is operated in a commercial environment. Operation of this equipment in a residential area is likely to cause interference, in which case the user at his own expense will be required to take whatever measures may be necessary to correct the interference.

Changes or modifications not expressly approved by the party responsible for compliance could void the user's authority to operate the equipment.

This digital apparatus does not exceed the Class A limits for radio noise emission from digital apparatus set out in the Radio Interference Regulation of Industry Canada.

Le présent appareil numérique n'émet pas de bruits radioélectriques dépassant les limites applicables aux appareils numériques de la classe A prescrites dans le Règlement sur le brouillage radioélectrique publié par Industrie Canada.

**NORMAS OFICIALES MEXICANAS (NOM)
ELECTRICAL SAFETY STATEMENT****INSTRUCCIONES DE SEGURIDAD**

1. Todas las instrucciones de seguridad y operación deberán ser leídas antes de que el aparato eléctrico sea operado.
2. Las instrucciones de seguridad y operación deberán ser guardadas para referencia futura.
3. Todas las advertencias en el aparato eléctrico y en sus instrucciones de operación deben ser respetadas.
4. Todas las instrucciones de operación y uso deben ser seguidas.
5. El aparato eléctrico no deberá ser usado cerca del agua—por ejemplo, cerca de la tina de baño, lavabo, sótano mojado o cerca de una alberca, etc..
6. El aparato eléctrico debe ser usado únicamente con carritos o pedestales que sean recomendados por el fabricante.
7. El aparato eléctrico debe ser montado a la pared o al techo sólo como sea recomendado por el fabricante.
8. Servicio—El usuario no debe intentar dar servicio al equipo eléctrico más allá a lo descrito en las instrucciones de operación. Todo otro servicio deberá ser referido a personal de servicio calificado.
9. El aparato eléctrico debe ser situado de tal manera que su posición no interfiera su uso. La colocación del aparato eléctrico sobre una cama, sofá, alfombra o superficie similar puede bloquea la ventilación, no se debe colocar en libreros o gabinetes que impidan el flujo de aire por los orificios de ventilación.
10. El equipo eléctrico deber ser situado fuera del alcance de fuentes de calor como radiadores, registros de calor, estufas u otros aparatos (incluyendo amplificadores) que producen calor.

11. El aparato eléctrico deberá ser conectado a una fuente de poder sólo del tipo descrito en el instructivo de operación, o como se indique en el aparato.
12. Precaución debe ser tomada de tal manera que la tierra física y la polarización del equipo no sea eliminada.
13. Los cables de la fuente de poder deben ser guiados de tal manera que no sean pisados ni pellizcados por objetos colocados sobre o contra ellos, poniendo particular atención a los contactos y receptáculos donde salen del aparato.
14. El equipo eléctrico debe ser limpiado únicamente de acuerdo a las recomendaciones del fabricante.
15. En caso de existir, una antena externa deberá ser localizada lejos de las líneas de energía.
16. El cable de corriente deberá ser desconectado del cuando el equipo no sea usado por un largo periodo de tiempo.
17. Cuidado debe ser tomado de tal manera que objetos líquidos no sean derramados sobre la cubierta u orificios de ventilación.
18. Servicio por personal calificado deberá ser provisto cuando:
 - A: El cable de poder o el contacto ha sido dañado; u
 - B: Objetos han caído o líquido ha sido derramado dentro del aparato; o
 - C: El aparato ha sido expuesto a la lluvia; o
 - D: El aparato parece no operar normalmente o muestra un cambio en su desempeño; o
 - E: El aparato ha sido tirado o su cubierta ha sido dañada.

CONTENTS

1. Specifications	6
2. Introduction	8
2.1 Functional Description	8
2.2 System Considerations	9
2.2.1 Data Transfer	9
2.2.2 Interfacing	9
2.2.3 T1 Interface	10
2.2.4 E1 Interface	10
3. Installation	11
3.1 General	11
3.2 What's Included in the Package	11
3.3 Site Requirements	11
3.4 Setting the Switches	12
3.4.1 Internal Switch Settings Information	12
3.4.2 Interface Jumper	12
3.4.3 Interface Grounding	13
3.4.4 Range	13
3.4.5 Optical Signaling	14
3.4.6 Electrical/Chassis Grounding	14
3.5 Installation in 19" Racks	16
3.5.1 Installation of a Single Unit	16
3.5.2 Installation of Two Units	17
3.6 Preparation for Operation	19
3.6.1 Grounding	19
3.6.2 Power Connection	19
3.6.3 Fiberoptics Connection	21
3.6.4 E1/T1 Cable Connection	21
4. Operation	22
4.1 Front Panel Indicators	22
4.2 Preparation for Operation, General	22
4.3 Operation Instructions	23
5. Troubleshooting	24

Appendix A: Functional Interface Specifications	25
Appendix B: DC Power-Supply Connection.	26

1. Specifications

- Compliance** — All models: FCC Class A, IC Class/classe A;
230-VAC (“-AE” suffix) models: CE
- Interfaces** — Device side:
All models: Either 100- Ω balanced (4-wire) T1, 100- Ω balanced (4-wire) E1; or 75- Ω unbalanced (coaxial) E1 (user-selectable);
Line side:
MT610 models: Multimode fiberoptic, 1300 nm;
MT611 models: Multimode fiberoptic, 850 nm;
MT613 models: Single-mode fiberoptic, 1300 nm
- Data Rate** — T1: 1.544 Mbps;
E1: 2.048 Mbps
- Receiver Sensitivity** — For BER=10⁻⁹: -38 dBm at 850 nm or -40 dBm at 1300 nm
- User Controls** — All internal:
(5) DIP switches for transmission range, grounding, and signal-loss handling;
(1) Slide switch for interface
- Diagnostic** — Dry-contact-closure alarm on DB15 Pins 6 and 13 for signal or power loss; minimum switching current 1 amp
- Indicators** — (2) Front-mounted LEDs: Power and Signal Loss

Connectors —	All rear-mounted: “-SM” models: (2) SMA female; “-ST” models: (2) ST female; “-FC” models: (2) FC female; All models: (1) DB15 for balanced T1 or E1 I/O; (2) BNC female for unbalanced E1 I/O
Maximum Altitude —	10,000 ft. (3048 m)
Temperature Tolerance —	32 to 122°F (0 to 50°C)
Humidity Tolerance —	0 to 90% noncondensing
Enclosure —	Steel
Power —	MT610-13A-xx: From internal power supply with cord: 103.5 to 126.5 VAC, 47 to 63 Hz; MT610-13AE-xx: From internal power supply with cord: 207 to 253 VAC, 47 to 63 Hz; MT610-13A-D48: From internal power supply with cord: -42 to -57 VDC at 60 mA; Consumption: 5 watts maximum
Size —	1.8" (1U) H x 7"W x 8.1"D (4.5 x 17.9 x 20.3 cm)
Weight —	3 lb. (1.1 kg)

2. Introduction

2.1 Functional Description

The T1/E1 Fiberoptic Line Driver is used for transmission of T1 (1.544 Mbps) and E1 (2.048 Mbps) data over multi-mode or single-mode fiberoptic media. The Line Driver is transparent to T1 and E1 framing, and can transmit data using any framing pattern with AMI, HDB3 or B8ZS coded signals.

The Line Driver converts the T1/E1 electrical signal into an optical signal using an infrared LED transmitter. At the opposite end of the fiber, the optical signal is converted back into an electrical signal and amplified to the required level. Automatic Gain Control (AGC) circuits are used to accommodate various distances. The Line Driver uses a Phase Locked Loop (PLL) circuit to recover data and clock from the signal. The Line Driver provides three user-selectable electrical interface options:

- T1—for 100 terminated balanced signals
- E1—for 120 terminated balanced signals
- E1—for 75 terminated unbalanced signals

Both a 15-pin connector and coaxial connectors are provided on the rear panel. Internal jumpers enable the input/output ports to be grounded or floating, according to the application.

Diagnostic and alarm features include an LED status indicator, all “ones” signaling (AIS) alarm generation, and dry contact closure upon link failure.

The Line Driver is designed to operate with several different grades and sizes of fiberoptic cable, and provides the user with:

- Immunity to electrical interference such as EMI, RFI, spikes and differential ground loops.
- Protection from sparking and lightning.
- A secure link in hazardous or hostile environments.

The standard version is supplied with an 850-nm multi-mode fiberoptic interface. A 1300 nm single- or multi-mode interface is also available.

The electrical interface meets requirements of AT&T PUB 62411 and CCITT G.703 for a T1 interface, and CCITT G.823 for an E1 interface. The Line Driver operates from either 100 VAC, 115 VAC, 230 VAC, or - 48 VDC. The unit comes in a compact standalone case that can be placed on a desktop or shelf, or can be mounted in a 19-inch rack (with adapters).

2.2 System Considerations

The Line Driver provides a simple and reliable means for transmitting full-duplex T1 or E1 signals via a fiberoptic medium.

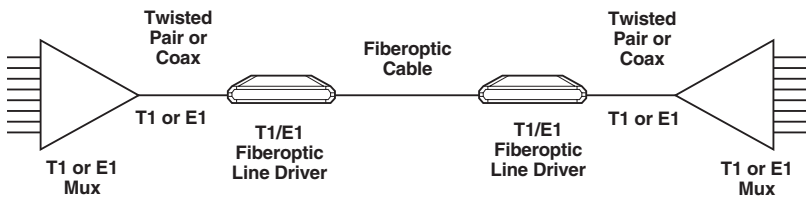

Figure 2-1. Typical Line Driver Application.

2.2.1 DATA TRANSFER

In the application illustrated in **Figure 2-1**, each Line Driver receives T1 or E1 signals which are equalized to overcome electrical link distortion. The Line Driver then converts the T1 or E1 signals into an optical signal. The optical signal is coupled to the fiberoptic media and transmitted via the optical link to the remote unit. The optical output power is user-selectable by a two-position switch marked Range. Its setting depends on the fiberoptic link. A high-sensitivity pre-amplifier and an AGC (Automatic Gain Control) circuit enable the remote unit to receive the optical signal. The output of the receiver is applied to the clock-recovery and data-regeneration circuit which then applies it to the electrical interface driving circuit.

2.2.2 INTERFACING

The electrical interface is selectable by means of a three-position internal INTERFACE switch.

2.2.3 T1 INTERFACE

The T1 interface fully complies with requirements of AT&T PUB 62411 and G.703. Two types of line coding can be used: AMI or B8ZS. Select the T1 interface by setting the INTERFACE switch to the left position.

2.2.4 E1 INTERFACE

The Line Driver's E1 interface fully complies with the applicable CCITT recommendations (pulse mark and HDB-3 line coding per CCITT Rec. G.823).

Select the E1 interface by setting the INTERFACE switch to the middle position for balanced signals or to the right position for unbalanced signals.

3. Installation

3.1 General

The Line Driver is a standalone unit. Special hardware for mounting the unit in a 19-inch rack can be ordered separately (request part number RM523). This hardware lets you install either a single unit or two units side-by-side using minimal rack space of 1U (1.72") in height.

This chapter provides mechanical and electrical installation procedures for the Line Driver. Before installing the unit, refer to **Sections 3.4** and **3.5** for internal switch setting procedures and additional information.

If you encounter a problem, refer to **Chapter 5** for troubleshooting instructions.

3.2 What's Included in the Package

1. After unpacking the Line Driver, inspect the unit for damage. If you notice damage, call Black Box immediately. The package contains the following:

- Line Driver
- Power cord
- This user's manual

2. Place the Line Driver securely on a clean surface.

3.3 Site Requirements

Install the Line Driver within 5 feet (1.5 m) of a grounded AC outlet capable of furnishing the rated voltage of the unit (100, 115, 230 VAC or - 48 VDC).

The ambient operating temperature of the T1/E1 FOLD should be 32 to 122 °F (0 to 50°C) at a relative humidity of up to 90%, non-condensing.

3.4 Setting the Switches

WARNING

Disconnect the unit from the power line before removing cover.

HIGH VOLTAGE—Any adjustment, maintenance, and repair of the opened instrument under voltage should be avoided as much as possible and should be carried out only by a skilled person who is aware of the hazard involved.

Capacitors inside the instrument may still be charged even after the instrument has been disconnected from its source of supply.

To change the switch settings, follow these steps:

1. Disconnect the power cable from the mains outlet.
2. Gain access to the Line Driver interior. Release the two rear panel screws and use them as levers to pull out the interior of the unit as a drawer.
3. Identify the switches, according to Figure 3-1.
4. Install the switches in the desired positions (refer to **Section 3.5**).
5. Reinstall the Line Driver drawer.

3.4.1 INTERNAL SWITCH SETTINGS INFORMATION

Before installing the Line Driver, set the internal switches according to your application (that is, electrical interface and optical link characteristics). The switches are located on the Line Driver board, as shown in **Figure 3-1**. Switch functions are also listed in **Table 3-2**.

3.4.2 INTERFACE JUMPER

The interface jumper (item 4 in **Figure 3-1**) selects one of three interface options:

- 100 (for T1 balanced signals, usually applied by the DB15 connector).
- 120 (for E1 balanced signals, usually applied by the DB15 connector).
- 75 (for E1 unbalanced signals, usually applied by the two BNC connectors).

3.4.3 INTERFACE GROUNDING

Both Input and Output can be individually grounded by means of two 2-position GROUNDED/FLOATING switches (items 2 and 3 in **Figure 3-1**).

3.4.4 RANGE

RANGE (item 1 in **Figure 3-1**) selects the optical output power coupled to the fiber, depending on the fiber core diameter. **Table 3-1** summarizes the optional output power available at the transmitter as a function of the wavelength and the type of fiber used.

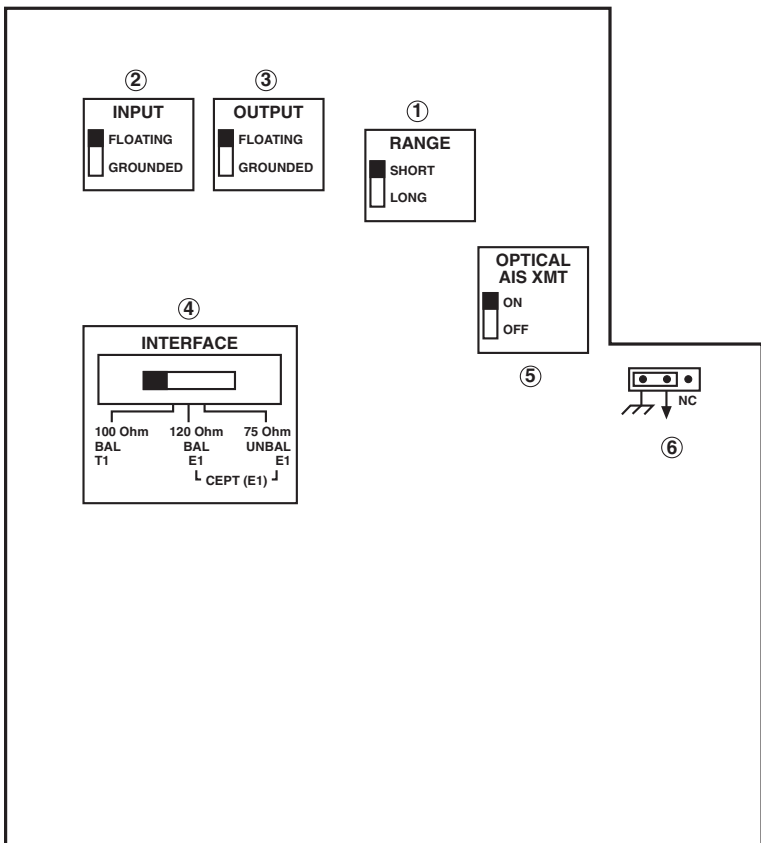

Figure 3-1. Location of Switches and Jumpers.

3.4.5 OPTICAL SIGNALING

In the event of a received optical signal loss, the Line Driver sends an all “ones” signal (AIS) at a nominal frequency of 50 ppm. When the optical signalling switch (item 5 in **Figure 3-1**) is OFF, the AIS signal is only sent to the electrical interface of the local unit. When the switch is set to ON, an AIS optical signal is also sent to the remote unit via the transmit optical link.

3.4.6 ELECTRICAL/CHASSIS GROUNDING

This jumper (item 6 in **Figure 3-1**) disconnects (NC) or connects the chassis ground to electrical ground.

WARNING

Setting the jumper to disconnect may render the Line Driver unsafe for connection to unprotected E1/T1 networks in some locations where permanent excessive voltages are present on the lines.

Table 3-1. Range Switch Position.

Switch Position	Fiber Type	Power coupled into fiber and maximum transmission distance			
		850 nm dBm	1300 nm km*	dBm	km*
SHORT (for 850 nm version only)	9/125	-	-	-	-
	50/125	-33	1.5	-	-
	62.5/125	-29	2.2	-	-
	100/140	-25	2.8	-	-
LONG	9/125	-	-	-27	16.0
	50/125	-23	5.0	-20	19.0
	62.5/125	-19	5.0	-16	16.0
	100/140	-15	5.0	-12	14.0

*Based on commercially available fiberoptic cables.

NOTE

The receiver saturates at about -20 dBm. In order to avoid saturation, set the RANGE switch to the SHORT position whenever the power at the receiver exceeds this level.

The receiver sensitivity at 850 nm is -38 dBm.

The receiver sensitivity at 1300 nm is -40 dBm.

Table 3-2. Internal Switches and Jumpers.

No.	Microswitch/ Jumper	Function	Possible Settings	Factory Setting
1	RANGE	Selects high (long-range) optical output or low (short-range) optical output.	LONG SHORT	SHORT
2	INPUT (Interface Grounding)	Enables connection of the INPUT BNC shield to Chassis Ground.	GROUNDING FLOATING	FLOATING
3	OUTPUT (Interface Grounding).	Enables connection of the OUTPUT BNC shield to Chassis Ground.	GROUNDING FLOATING	FLOATING
4	INTERFACE	Selects the electrical interface.	100 Ω T1 DB15 155 V 120 Ω E1 DB15 220 V 75 Ω E1 BNC	T1 100 Ω DB15 or E1 120 Ω DB15
5	OPTICAL AIS XMT	In event of optical signal loss, sends all “ones” optical signalling at ±50 ppm to the remote unit (in addition to the all “ones” signalling sent to the local electrical interface).	ON-AIS signal transmitted both electrically (to local unit) and optically (to remote unit). OFF-AIS signal transmitted electrically only (to local unit).	OFF

Table 3-2 (continued). Internal Switches and Jumpers.

No.	Microswitch/ Jumper	Function	Possible Settings	Factory Setting
6	Electrical/Chassis Grounding	Sets the unit to chassis ground either connected or not connected to electrical ground.	Chassis gnd. connected to electrical gnd. NC Chassis gnd. not connected to electrical gnd.	Chassis gnd. connected to electrical gnd.

NOTE

Setting INPUT and OUTPUT to GROUNDED connects the BNCs (coax) shield to Chassis Ground. Therefore, this setting is valid when using coax cables only. When using a 4-wire connection, set INPUT and OUTPUT to FLOATING.

3.5 Installation in 19-inch Racks

The Line Driver can be installed in a 19-inch rack. Its height is slightly less than 1U (1.75”), and the width is slightly less than half of the available mounting width. A rack adapter kit (part number RM523, which contains one long bracket, two short brackets, and a rail), is available for installation of either a single unit or two units side by side.

WARNING

Disconnect the units from mains power while performing the following procedures.

3.5.1 INSTALLATION OF A SINGLE UNIT

The rack adapter components for single unit installation include one short bracket and one long bracket. The brackets are fastened by means of screws to the side walls for the case, as shown in **Figure 3-2**. The sort bracket attaches to the left side of the unit and the long bracket to the right side of the unit.

1. To prepare the unit for rack installation, attach the two brackets to the side walls of the unit. Each bracket is fastened by means of two screws (with flatwashers), which are inserted into the two front holes on the wide wall (nuts are already in place, on the inner side of the wall).
2. After attaching the brackets, the unit is ready for installation in the 19" rack. Fasten the brackets to the side rails of the 19" rack by means of four screws—two per side (included).

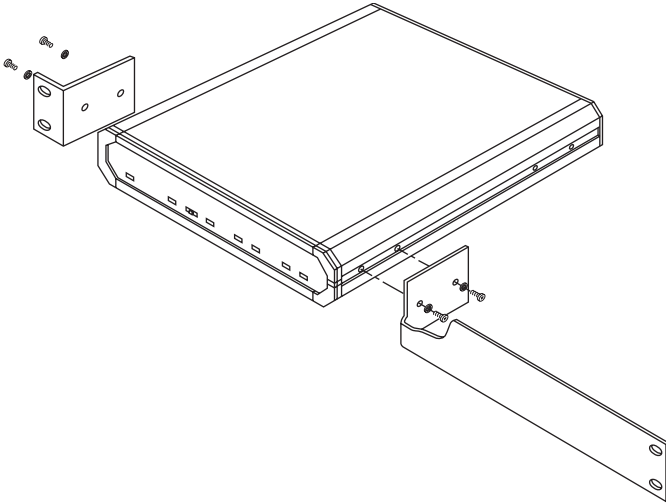

Figure 3-2. Installation of a Single Unit in a 19" Rack.

3.5.2 INSTALLATION OF TWO UNITS

The rack adapter components for two units include two long side rails (one for each unit), which slide one within the other to fasten the two units together, and two short side brackets which fasten the two units to the 19" rack (refer to **Figure 3-3**).

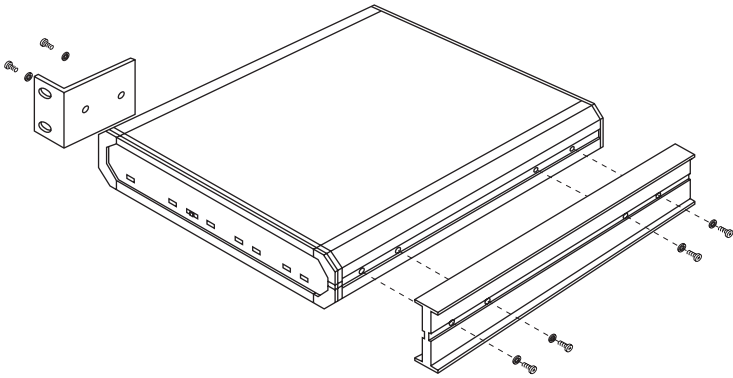

Figure 3-3. Installation of Two Units in a 19" Rack (a).

To install two units:

1. Attach a long side rail to each unit (right side for one unit, left side of the other unit) using the 4 screws and flat washers supplied. The long side rails must be attached in opposing fashion, with the narrow flange of the first rail opposite the wide flange of the second rail.
2. Attach a short bracket to the other side of each unit using the 4 screws and flat washers supplied.

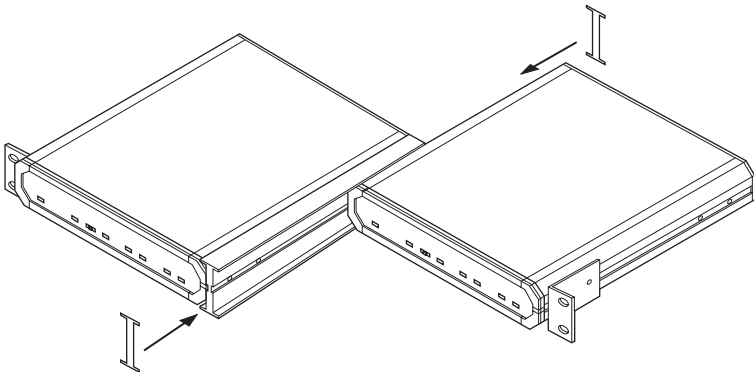

Figure 3-4. Installation of Two Units in a 19" Rack (b).

3. Slide one unit side rail within the other, so as to fasten the two units together (refer to **Figure 3-4**).
4. Secure the plastic cups supplied to the ends of the joined rails, to prevent the units from sliding and to protect the rail ends.
5. The assembled units can now be fastened to the side rails of the 19" rack, by means of four screws—two per side (not included in the kit).

3.6 Preparation for Operation

After setting the Line Driver's internal switches, as described in **Sections 3.4** and **3.5**, the Line Driver is ready for operation.

3.6.1 GROUNDING

For your protection, the Line Driver must always be grounded. Any interruption of the protective (grounding) conductor (inside or outside the instrument) or disconnecting the protective earth can make this instrument dangerous. Intentional interruption is prohibited.

3.6.2 POWER CONNECTION

Power should be supplied to the Line Driver through the standard power cable terminated by a standard 3-prong plug. Connect the cable between the mains connector on the Line Driver rear panel and a standard grounded mains outlet.

WARNING

The protective earth terminals of this instrument must be connected to the protective conductor of the (mains) power cord. The mains plug must only be inserted in a socket outlet provided with a protective earth contact. The protective action must not be negated by use of an extension cord (power cable) without a protective (grounding) conductor.

Make sure that only fuses with the required rated current are used for replacement. The use of repaired fuses and the short-circuiting of fuse holders must be avoided.

Whenever it is likely that the protection offered by fuses has been impaired, the instrument must be made inoperative and secured against any unintended operation.

WARNING

The unit has no power switch. Its operation starts when power is applied to the POWER connector. When applying power, first connect the plug of the power cable to the Line Driver POWER connector and then to the mains.

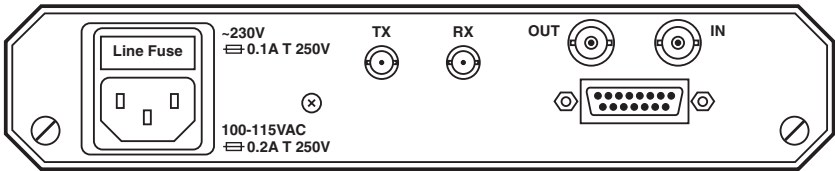

Figure 3-5. Line Driver Rear Panel.

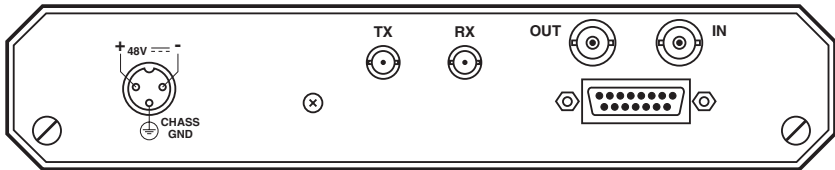

Figure 3-6. Pinout of -48 VDC Power Jack.

3.6.3 FIBEROPTICS CONNECTION

Two fiberoptic SMA, ST or FC connectors are located on the rear panel, marked TX and RX. Remove the protective caps from the connectors and store them in a safe place for later use. Connect the transmit fiber to the connector marked TX and the receive fiber to the connector marked RX. At the remote unit, the transmit fiber must be connected to RX and the receive fiber to TX.

3.6.4 E1/T1 CABLE CONNECTION

E1 or T1 link connections depend on the selected interface:

- 120 Ω or 100 Ω balanced interface. Connect to the DB15 female connector located on the rear panel. Refer to Appendix A for information on the wiring of the DB15 connector.
- 75 Ω unbalanced E1 interface. Connect to the two coaxial connectors designated OUT and IN.

NOTE

Only one of the two E1 connection possibilities may be used: never connect cables to both the coaxial connectors and to the DB15 connector at the same time.

4. Operation

4.1 Front Panel Indicators

Table 4-1 lists the functions of the Line Driver indicators, located on the front panel, as shown in Figure 4-1.

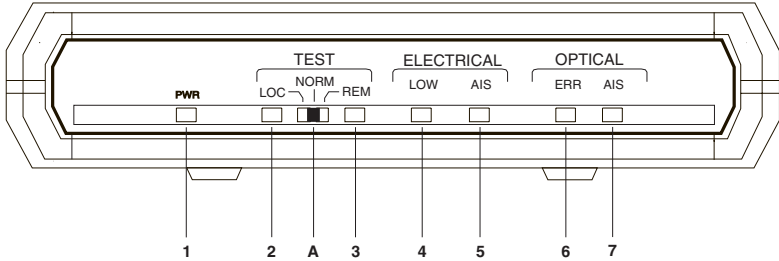

Figure 4-1. Front Panel of the Line Driver.

Table 4-1. Line Driver Indicators.

Item	Indicator	Function
1	Power	Lights when the Line Driver operates.
2	Signal Loss	Lights when optical signal is below -43 dBm, or, in some cases, when there is no connection to G.703 port.

4.2 Preparation for Operation, General

After being prepared for operation according to **Chapter 3**, the Line Driver normally operates unattended. Operator intervention is only required when the Line Driver is set up for the first time or must be adapted to new operational requirements that require changing the internal switch settings.

4.3 Operation Instructions

1. Power On. The Line Driver is turned on as soon as power is connected. When power is connected, the POWER indicator lights, and remains lit as long as power is available.
2. Normal Operation Indications. During normal operation the SIGNAL LOSS indicator is off.
3. Upon power-on, the SIGNAL LOSS indicator may light, indicating that other communication equipment is not yet operating or that the optical signal is below -43 dBm. The indicator will turn off as soon as all link equipment is operating.
4. Power-off. The Line Driver is turned off by disconnecting its power. Always disconnect the power cable from the mains outlet first.

5. Troubleshooting

In case a problem occurs, refer to **Table 5-1**. Perform the actions listed under “Corrective Measures” in the order given until the problem is corrected.

Table 5-1. Troubleshooting Chart.

Symptom	Probable Causes	Corrective Measures
POWER indicator is OFF.	No AC power. Blown fuse. Defective Line Driver.	Make sure that both ends of the AC power cable are connected properly. Replace with fuse of proper rating. Replace the Line Driver.
SIGNAL LOSS indicator lights.	Incorrect optical signal level received at the receiver input. No signal is present at the electrical interface.	(a) Make sure that the electrical interface is connected. (b) Make sure that the INTERFACE switch is set to the appropriate setting. (c) Make sure that the fiberoptic cable is properly connected to the RX connector. (d) Make sure that the remote unit power is on and the TX fiberoptic connector is connected properly. (e) Measure the optical levels on both ends (if possible) in order to check the optical link. Make sure that the RANGE switches for both units are set properly. (f) Replace the faulty Line Driver.

Appendix A: Functional Interface Specifications

DB15 Connector

The 15-pin D-type female connector has standard T1 and E1 interfaces. The pin allocation is described in **Table A-1**.

Table A-1. DB15 and BNC Connector.

Pin No.	Designation	Function	BNC Connection
1	Send Data (TIP)	Transmit Data A wire (Line Driver input)	Center
9	Send Data (RING)	Transmit Data B wire (Line Driver input)	Shield
3	Receive Path (TIP)	Receive Data A wire (Line Driver output)	Center
11	Receive Path (RING)	Receive Data B wire	Shield
6	Alarm (A)		
13	Alarm (B)		

Appendix B: DC Power-Supply Connection

NOTE

Ignore this appendix if your unit operates on AC power.

The DC powered unit comes with a standard 3-pin (male) connector located at the unit rear (see **Figure B-1**). Supplied with the unit is a compatible (female) cable connector for attaching to your power-supply cable.

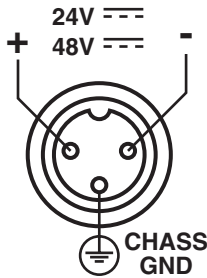

Figure B-1. Standard 3-pin male DC connector.

Voltage Polarity for the Power-Supply Cable

- If your power-supply cable already has a compatible connector, just verify that the voltage polarity is as required.
- If not, connect the wires of your power-supply cable to the supplied cable connector, according to the voltage polarity shown below in **Figures B-2** and **B-3**. Note that the solder side of the connector is shown. Refer to the illustration of the cable connector assembly (**Figure B-4**) for assistance.

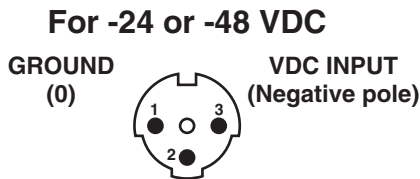

Figure B-2. Cable connector (female) voltage polarity for -24 or -48 VDC.

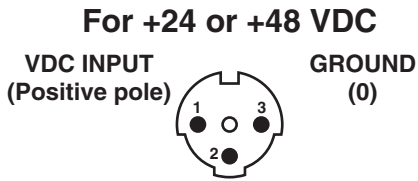

Figure B-3. Cable connector (female) voltage polarity for +24 or +48 VDC.

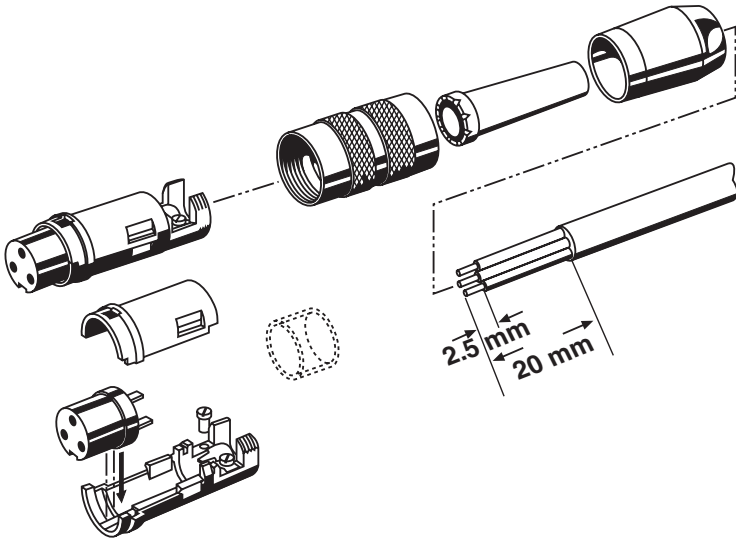

Figure B-4. Cable connector assembly.



© Copyright 1998. Black Box Corporation. All rights reserved.

1000 Park Drive • Lawrence, PA 15055-1018 • 724-746-5500 • Fax 724-746-0746