



© Copyright 2000. Black Box Corporation. All rights reserved.

1000 Park Drive • Lawrence, PA 15055-1018 • 724-746-5500 • Fax 724-746-0746



JANUARY 2000

RF200A	RF208	RF305
RF201	RF209	RF307
RF202	RF210	RF308
RF203	RF300A	RF309
RF204	RF301	RF310
RF205	RF302	RF199A-RKMT
RF207	RF304	RF299A-RKMT

Elite SC and Accessories

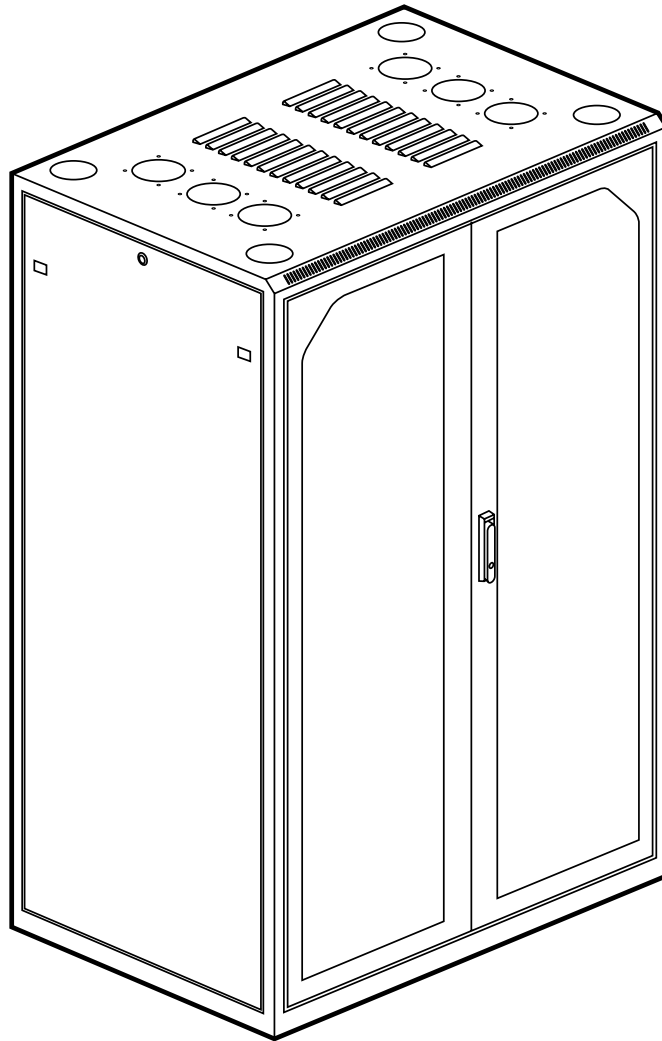

**CUSTOMER
SUPPORT
INFORMATION**

Order **toll-free** in the U.S.: Call **877-877-BBOX** (outside U.S. call **724-746-5500**)
FREE technical support 24 hours a day, 7 days a week: Call **724-746-5500** or fax **724-746-0746**
Mailing address: **Black Box Corporation**, 1000 Park Drive, Lawrence, PA 15055-1018
Web site: www.blackbox.com • E-mail: info@blackbox.com

TRADEMARKS USED IN THIS MANUAL

Plexiglas is a registered trademark of Rohm & Haas Company.

Any other trademarks mentioned in this manual are acknowledged to be the property of the trademark owners.

Contents

Chapter	Page
1. Elite SC	3
2. Elite SC with Installed Dual 19" EIA Mounting Kit, 39U.....	7
3. 19" EIA Rackmounting Kit, 5U	11
4. Shelves	12
5. Sliding Keyboard Trays.....	14
6. Horizontal Cable Management with Four Cable Rings.....	16
7. Vertical Cable Management with Six Cable Rings	17
8. Casters and Fan Assemblies	19

1. Elite SC

Available Models

The Elite SC is available in two colors: black (RF200A) and beige (RF300A).

Description

The Elite SC is a double-wide cabinet that's big enough to house your LAN equipment and act as a standalone data center. The cabinet is constructed with a rugged 14-gauge folded-steel frame, and it holds 700 pounds (317.5 kg) of equipment. It's preassembled, so it's easy to set up and use. Cabinet components include: fully louvered rear door, one pair of solid lift-off side panels, one 16-position power strip with circuit breaker and 12-ft. (3.7-m) cord, a Plexiglas® front door, two stationary shelves (300-pound capacity each), rubber feet, and leveling glides. Cabinet dimensions are 72"H x 48"W x 32"D (182.9 x 121.9 x 81.3 cm).

Additional features:

- Top panel has cable-management punch-outs, plus vented slots for extra cooling.
- Extra wide (48") and extra deep (32") for accommodating servers and other large equipment.
- Plexiglas front doors and vented rear doors have three-point latch and lock.

See pages 4 through 6 for diagrams.

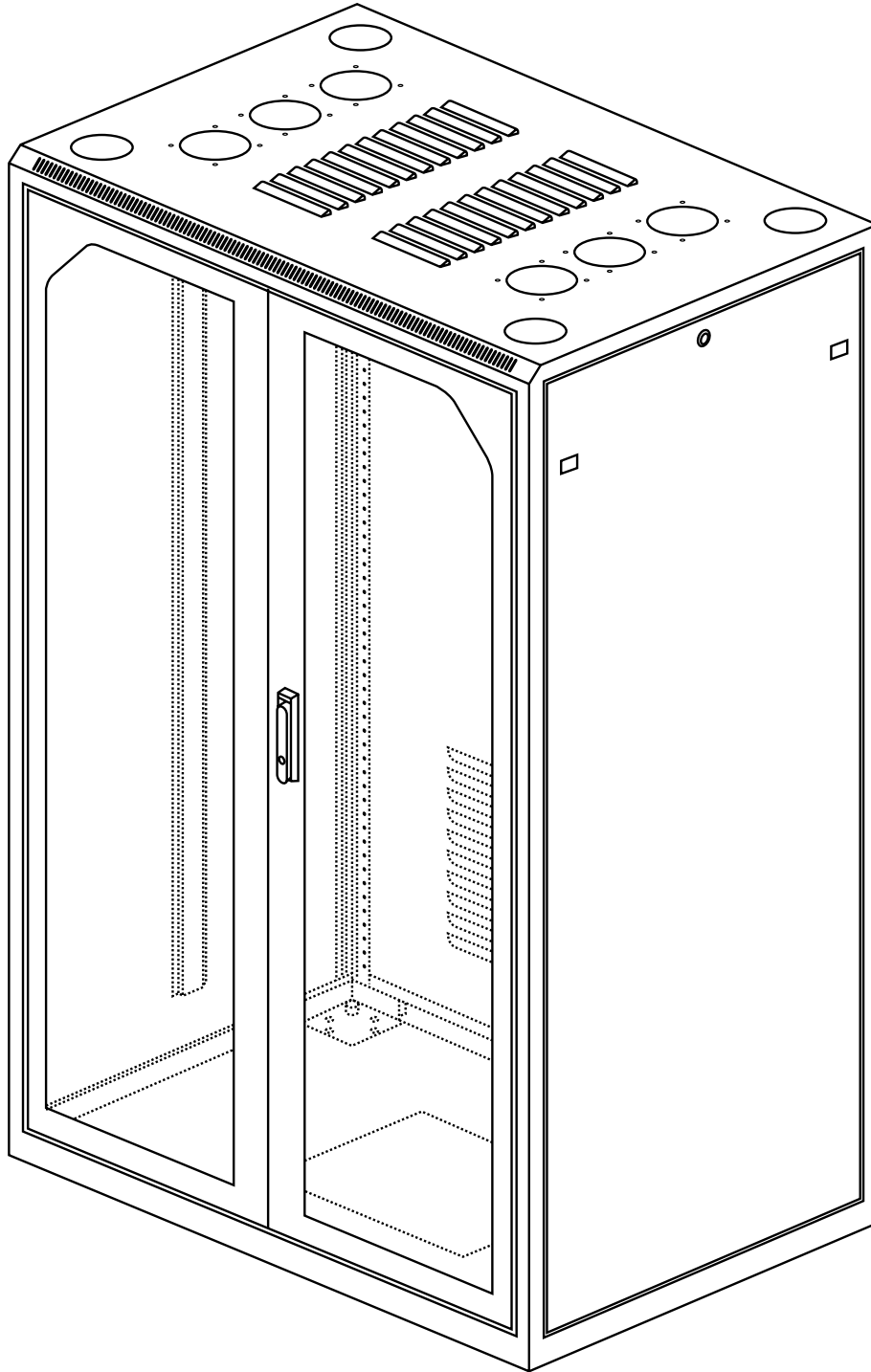

Figure 1-1. The Elite SC, front view.

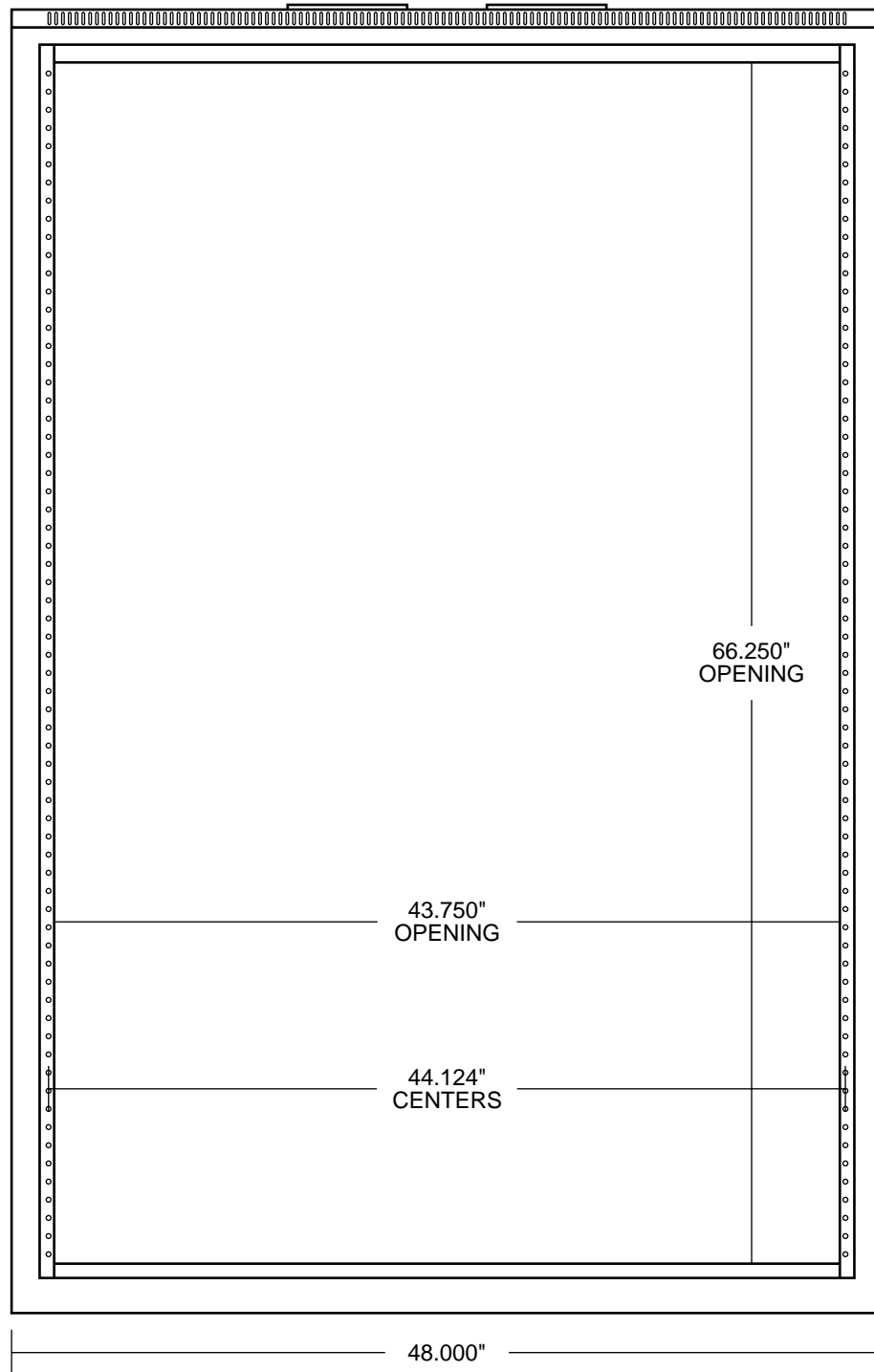

Figure 1-2. Front view of the Elite SC with the front door removed.

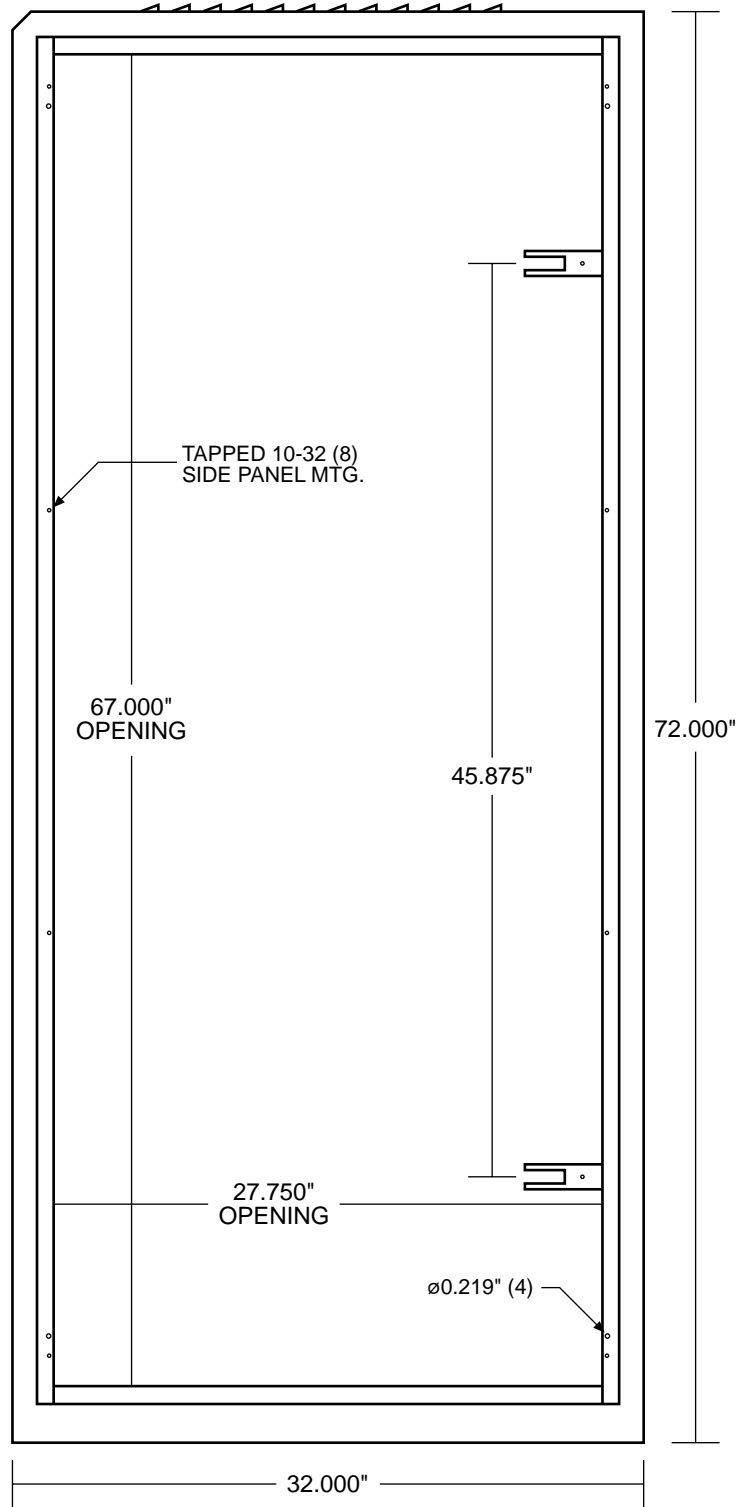

Figure 1-3. Right-side view of the Elite SC with the side panel removed.

2. Elite SC with Installed Dual 19" EIA Mounting Kit, 39U

Available Models

The Elite SC with Installed Dual 19" EIA Mounting Kit is available in two colors: black (RF199A-RKMT) and beige (RF299A-RKMT).

Description

If you haven't done so already, read **Chapter 1** for more information about the Elite SC. This version of the cabinet also includes 19" EIA mounting rails that fit side by side in the cabinet. Eight mounting rails are provided, and the rails are adjustable in one-inch horizontal increments. Use the rails for two- or four-point equipment mounting. The mounting kit also increases the weight capacity of the cabinet from 700 pounds to 1000 pounds (454 kg). Best of all, when your order the RF199A-RKMT or RF299A-RKMT, we'll install the Rackmount Kit in your Elite SC!

NOTE

Please note that the Elite SC with the Dual Mounting Kit does NOT include the two stationary shelves.

See pages 8 through 10 for diagrams.

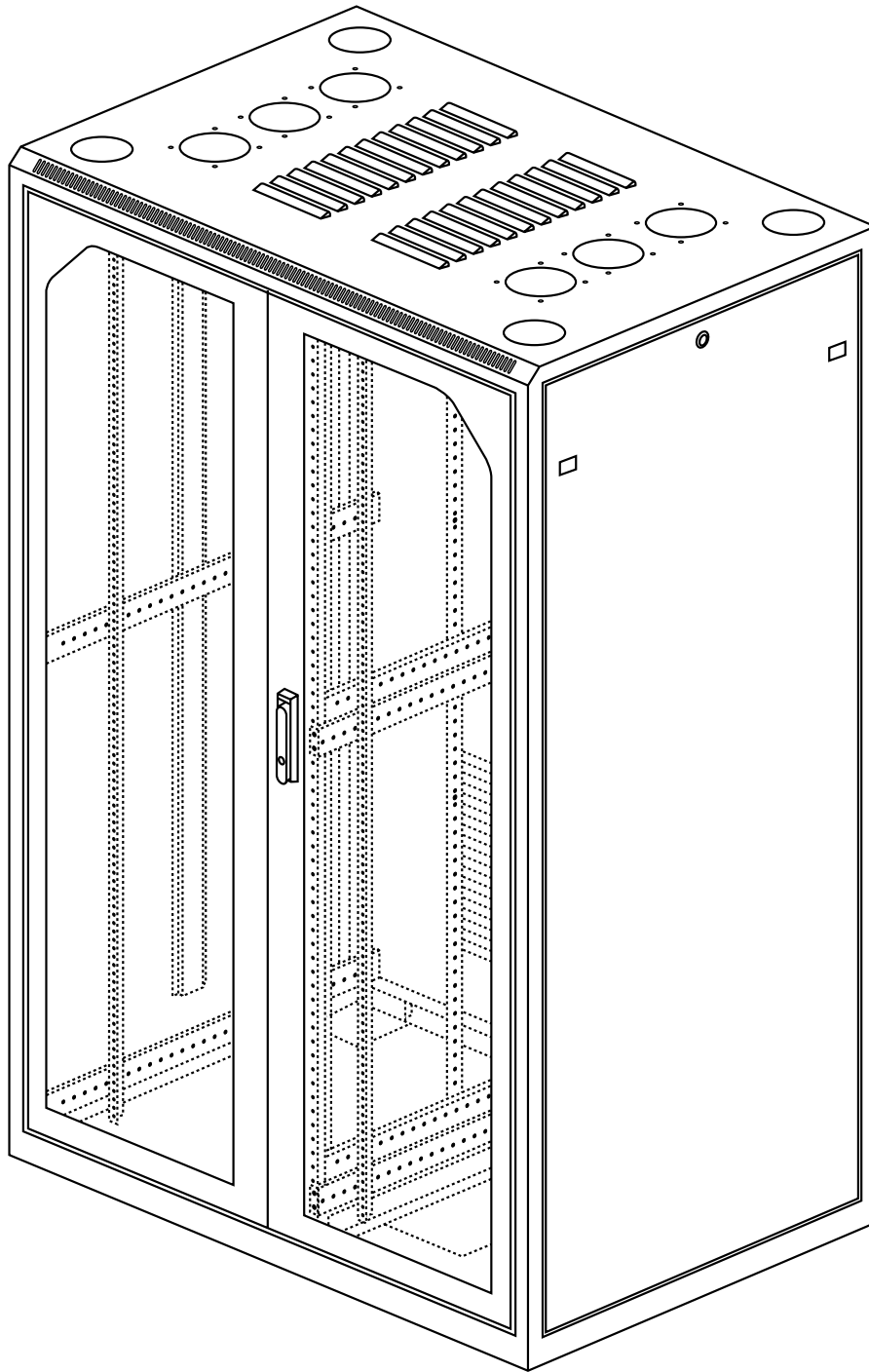

Figure 2-1. The Elite SC with Installed Dual 19" Mounting Kit.

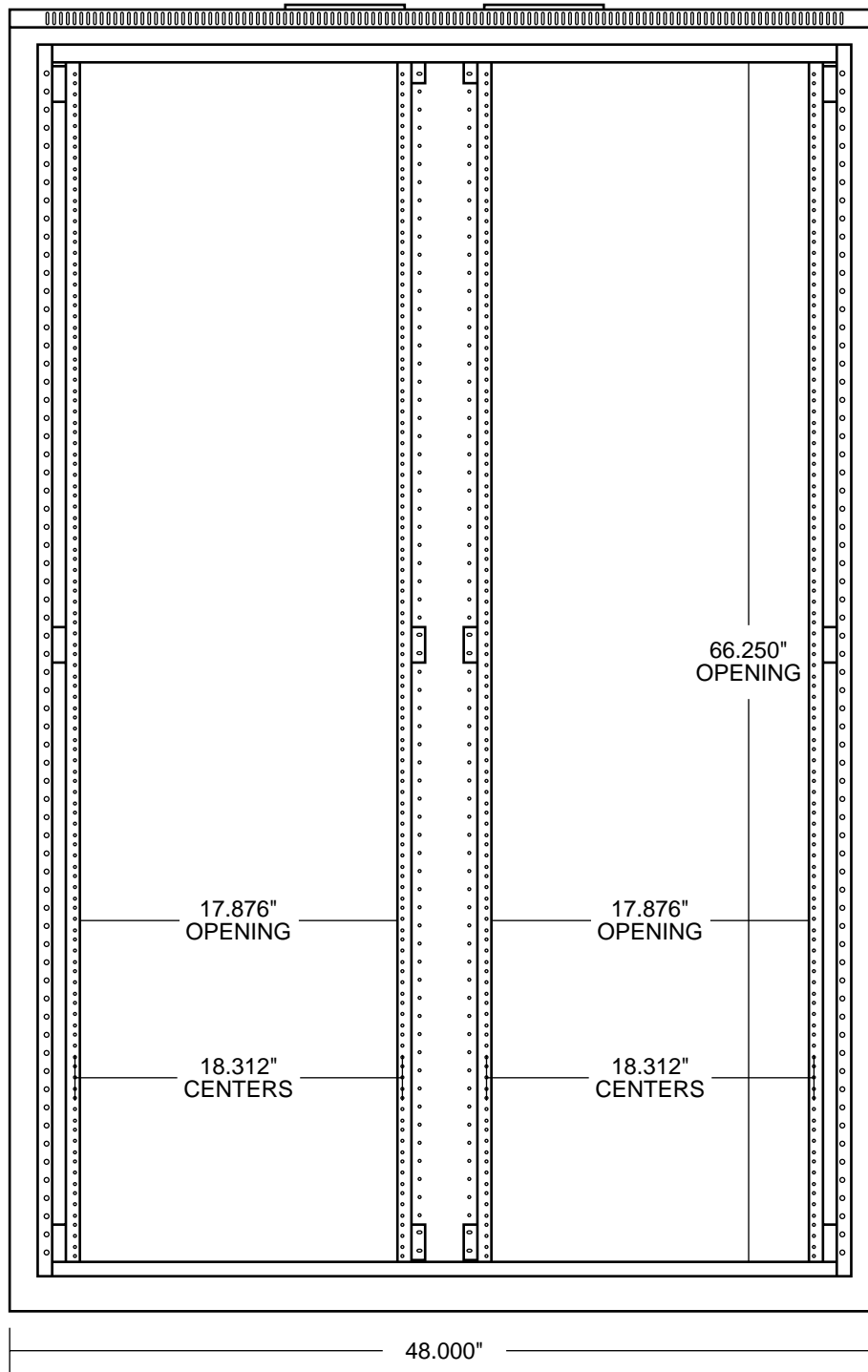

Figure 2-2. Front view of the Elite SC with Installed Dual 19" Mounting Kit (front door removed).

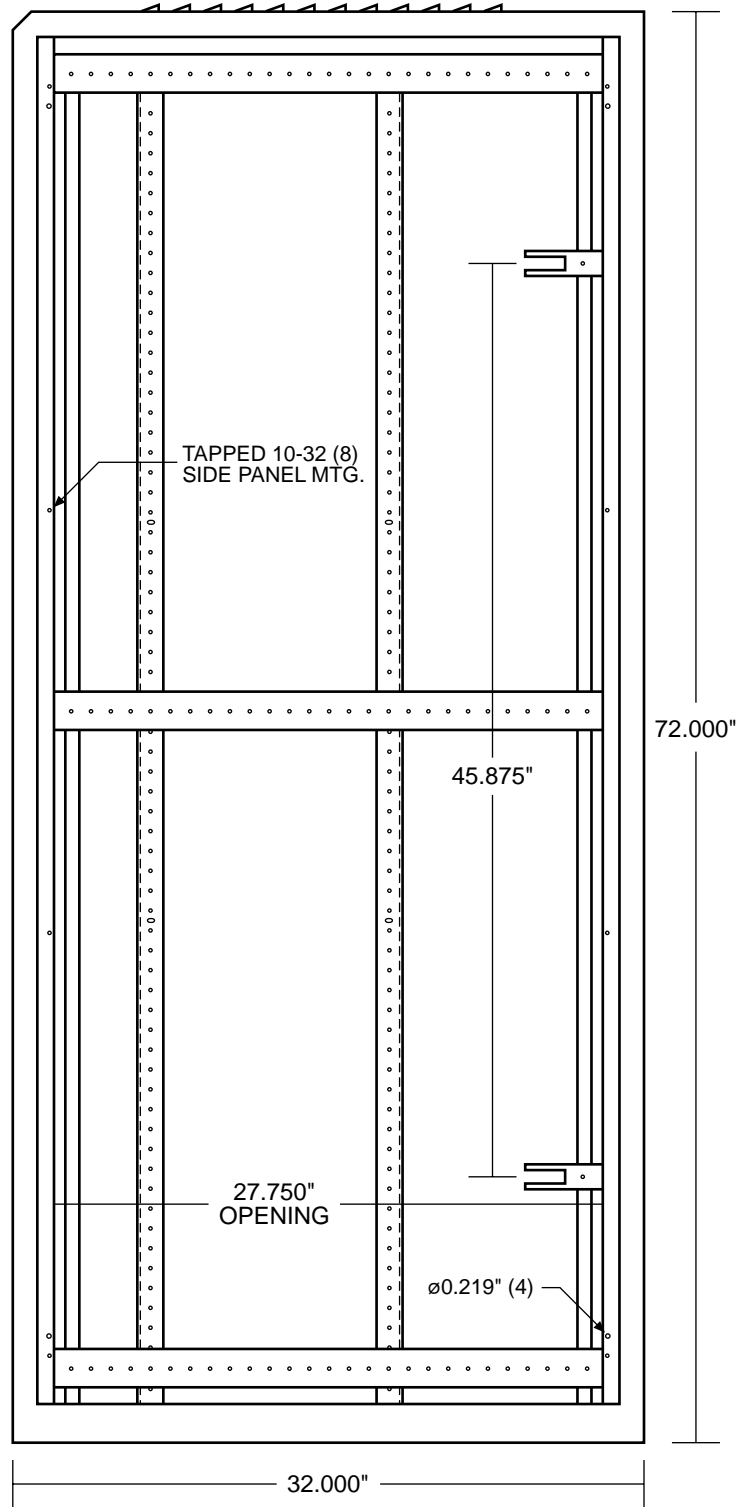

Figure 2-3. Right-side view of the Elite SC with Installed Dual 19" Mounting Kit (side panel removed).

3. 19" EIA Rackmount Kit, 5U

Available Models

The 19" EIA Rackmount Kit, 5U, is available in two colors: black (RF201) and beige (RF301).

Description

This is the perfect accessory for racking only a few patch panels or hubs. This Kit gives you an extra 5U for equipment.

The Kit includes: (1) 23.5"D stationary shelf, (2) mounting tabs, (2) rails, (1) support bar, (16) #12-24 screws, and (8) #10 washers.

Installation

Select the desired height to install the stationary shelf in the enclosure. Once you've picked the location, install the shelf using eight #10-32 screws. Tighten the screws.

Assemble the mounting tabs, rails, and support bar as shown using #12-24 screws and washers. Tighten all screws. This assembly is the RF201/RF301.

Attach the RF201/RF301 to the stationary shelf using #12-24 screws and washers. The two mounting tabs straddle the support bars underneath the shelf. The RF201/RF301 can be attached to any of the shelf slots. Tighten the screws.

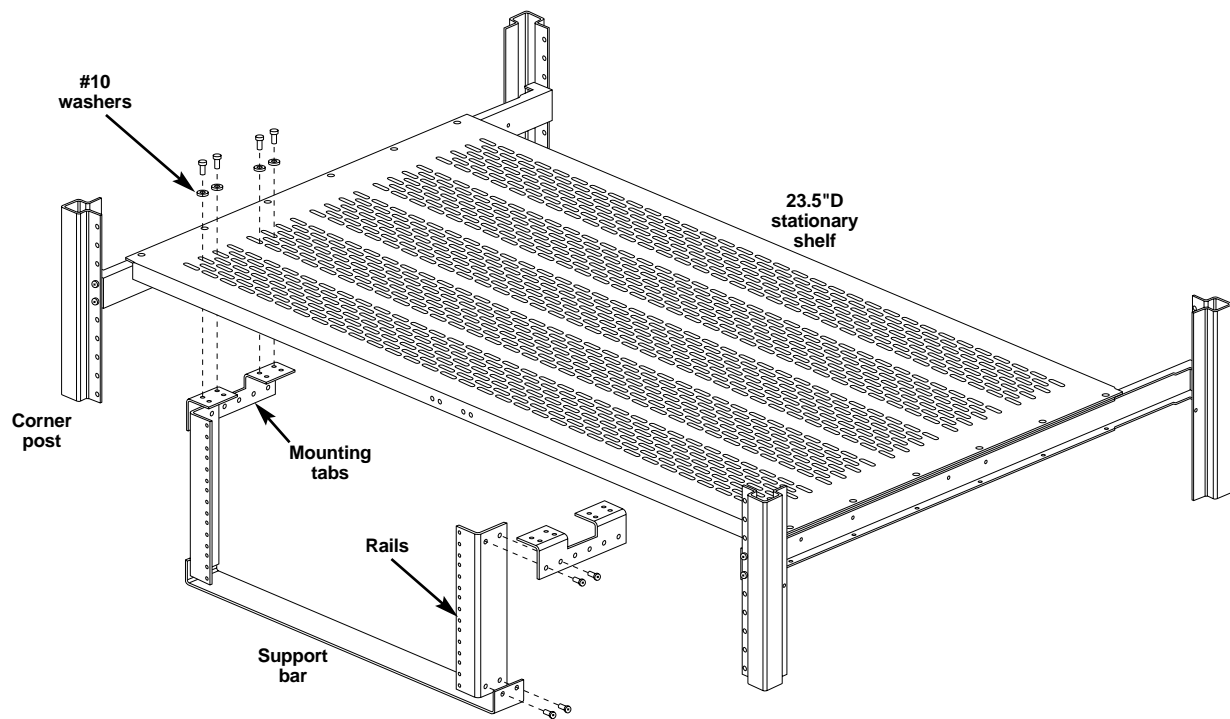

4. Shelves

Available Models

Two types of shelves are available: a stationary shelf and a sliding keyboard shelf. The stationary shelf is 44.75"W x 23.5"D (113.7 x 59.7 cm) and holds up to 300 pounds (136.2 kg). The sliding keyboard shelf is 42.5"W x 21.5"D (108 x 54.6 cm) and holds up to 35 pounds (15.9 kg).

The stationary shelf is available in two colors: black (RF202) and beige (RF302).

The sliding keyboard shelf is available in two colors: black (RF208) and beige (RF308).

Installation

STATIONARY SHELF

Select the desired height to install the shelf in the enclosure. Once you've picked the location, install the shelf using eight #10-32 screws. Tighten the screws. Add washers where indicated in the illustration below.

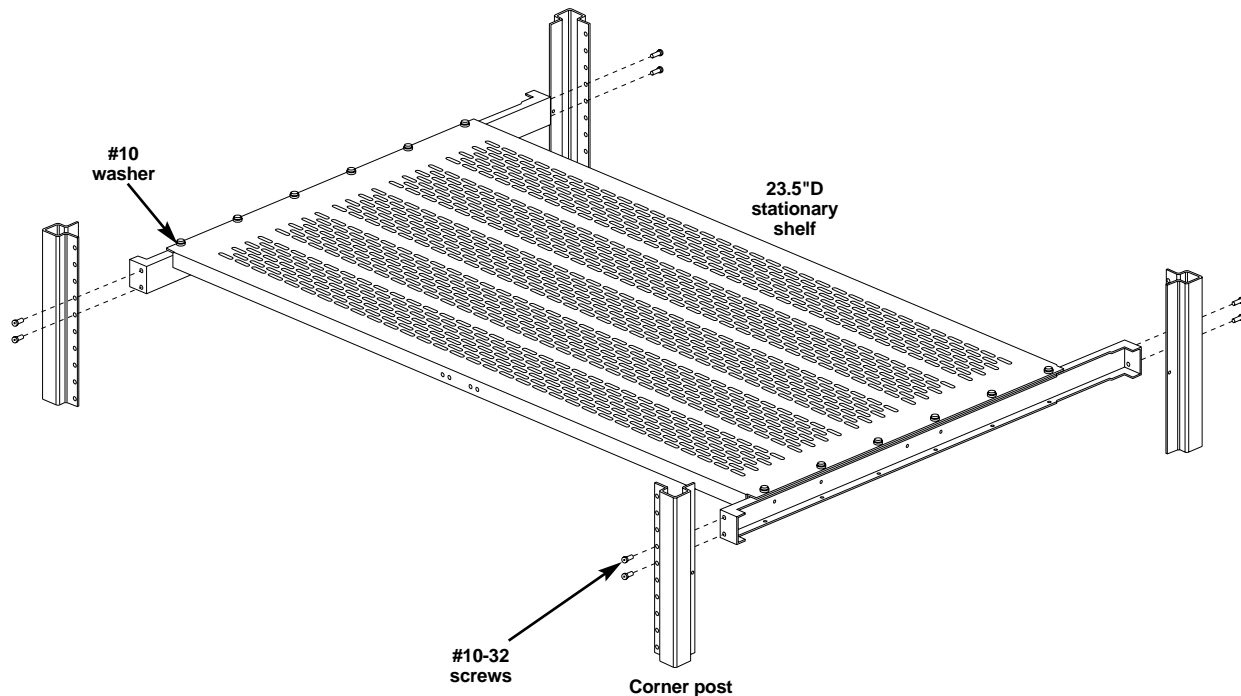

SLIDING KEYBOARD SHELF

Select the desired height to install the shelf in the enclosure. Once you've picked the location, install the shelf, with the slides facing into the enclosure, using eight #10-32 screws. Tighten the screws.

Slide the keyboard tray onto the outer slides. Push the keyboard tray all the way onto the slides so that the slides lock together.

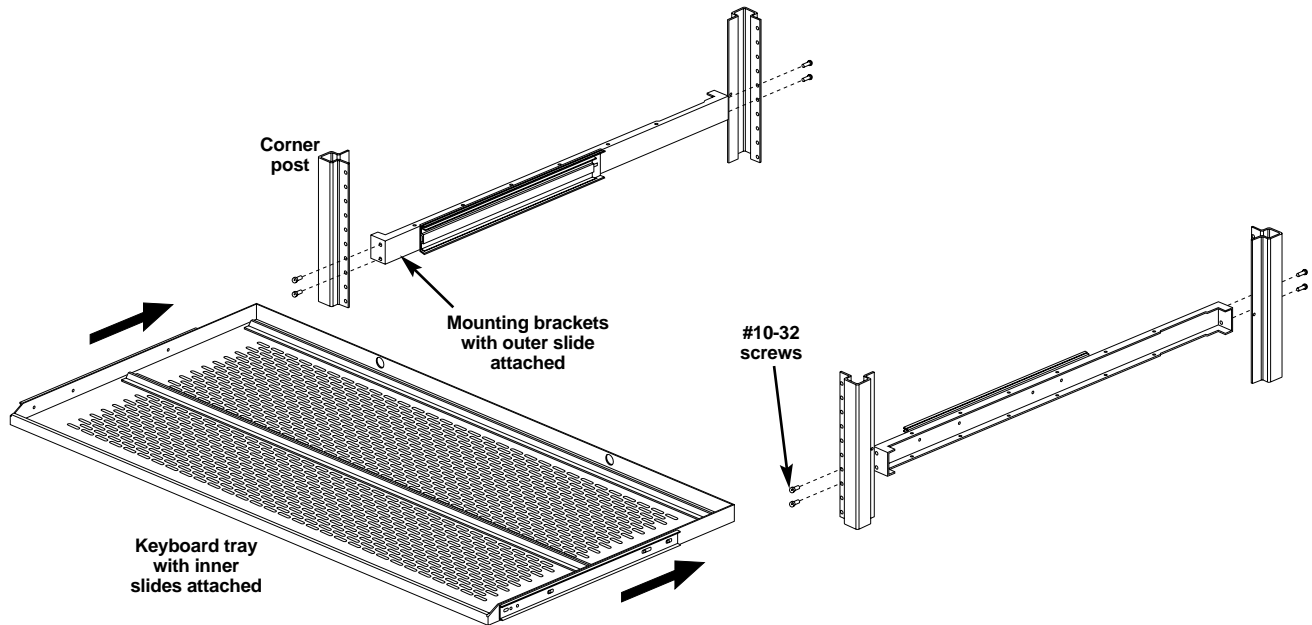

5. Sliding Keyboard Trays

Available Models

The Sliding Keyboard Trays are available in two colors (black and beige), and as a set of 2 or set of 4.

Set of 2, Black.....RF209

Set of 2, BeigeRF309

Set of 4, Black.....RF210

Set of 4, BeigeRF310

Description

These products give you either two or four vertically stacked keyboard trays to use with multiple keyboards. Just pull out the one you need. Trays measure 19.5"W x 15.56"D (49.5 x 39.52 cm), and include 16" slides, brackets, and one stationary shelf.

Installation

- 1) Select the desired height to install the tray in the enclosure. Once you've picked the location, install the tray using eight #10-32 screws. Tighten the screws.
- 2) Install the two 30.601" horizontal brackets (see the illustration on the next page) into the enclosure, directly under the stationary shelf (one on each side), with the slides facing into the enclosure. Use four #10-32 screws per bracket and tighten.
- 3) Install the hanging t-brackets on the shelf (one on the front and one on the back), using four #10-32 screws per bracket. *Do not tighten the screws.*
- 4) Install the two deep horizontal brackets onto the hanging t-brackets with the slides facing toward the 30.601" horizontal brackets. Use four #10-32 screws per bracket. *Do not tighten the screws.*
- 5) Slide the two keyboard trays onto the slides until they click into place. Now tighten the screws on the hanging brackets.

If you're installing the set of four trays, repeat steps 2 through 5.

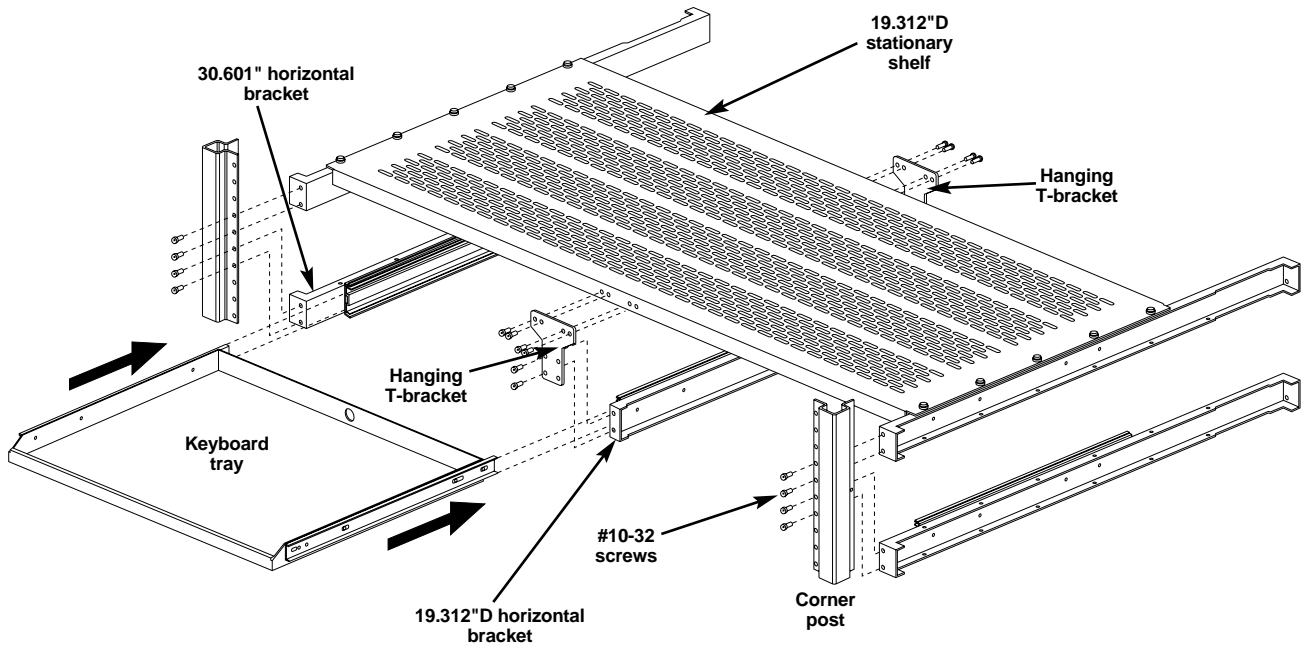

6. Horizontal Cable Management with Four Cable Rings

Available Models

The Horizontal Cable Management with Four Cable Rings is available in two colors: black (RF204) and beige (RF304).

Installation

Select the desired height to install the horizontal bracket in the enclosure. Once you've picked the location, install the bracket using four #10-32 screws. Tighten the screws.

Install the four rings at the desired location and orientation using two screws per ring. The rings should be mounted toward the interior of the enclosure.

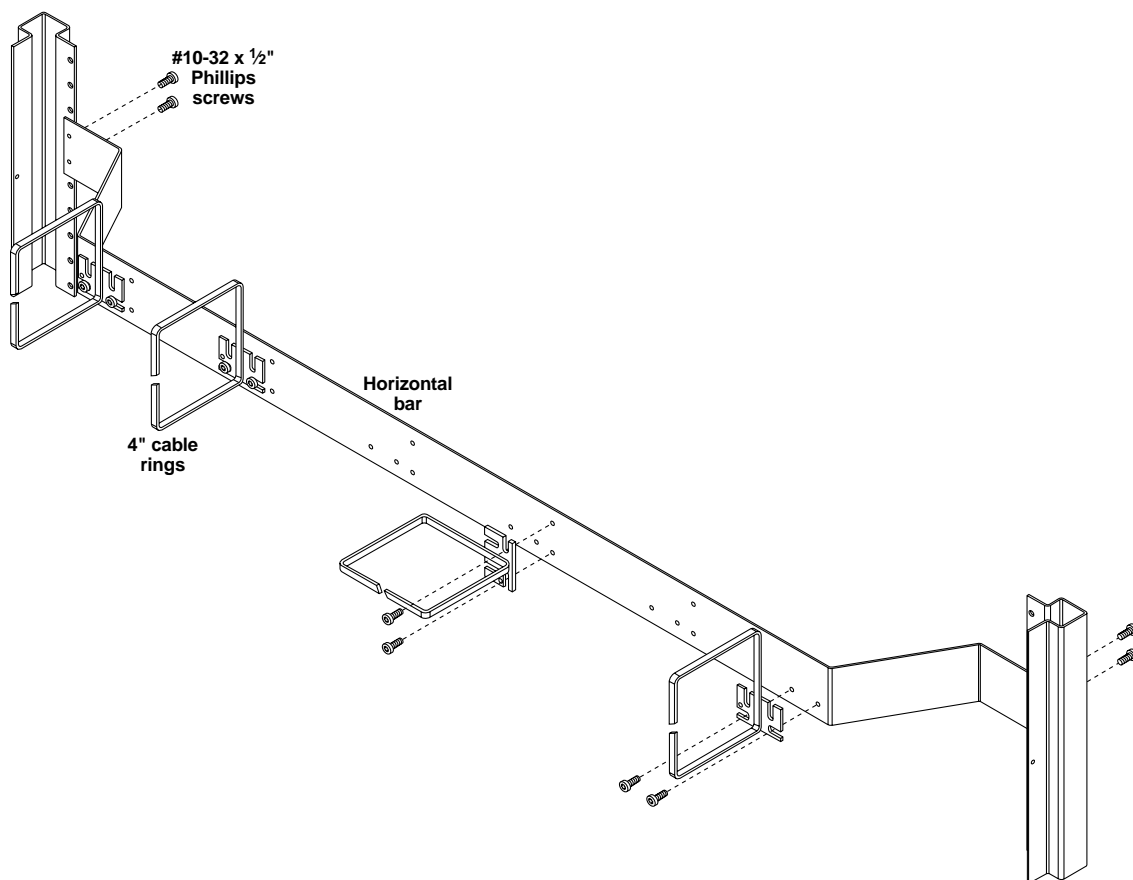

7. Vertical Cable Management with Six Cable Rings

Available Models

The Vertical Cable Management with Six Cable Rings is available in two colors: black (RF205) and beige (RF305).

Installation

- 1) Install the top and bottom mounting brackets in the enclosure (as shown on the next page) using two #10-32 screws per bracket. Mount these brackets as near to the top and bottom as possible, without interfering with a mounted shelf. There are four pairs of tapped holes on the mounting brackets, which can be used to mount the brackets to the enclosure. These holes allow 1½" of horizontal adjustment when mounting the vertical cable management. Tighten the screws.
- 2) Attach the two middle mounting brackets to the vertical bar using two #10-32 screws per bracket. The through holes on the mounting brackets need to line up with two of the tapped holes on the vertical bracket.
- 3) Attach the vertical bracket to the top and bottom mounting brackets (the ones you installed in step 1) with two #10-32 screws per bracket.
- 4) Attach the middle mounting brackets to the corner post using two #10-32 screws per bracket.
- 5) Install the six 4-inch cable rings at the desired location and orientation using two #10-32 screws per ring.

ELITE SC AND ACCESSORIES

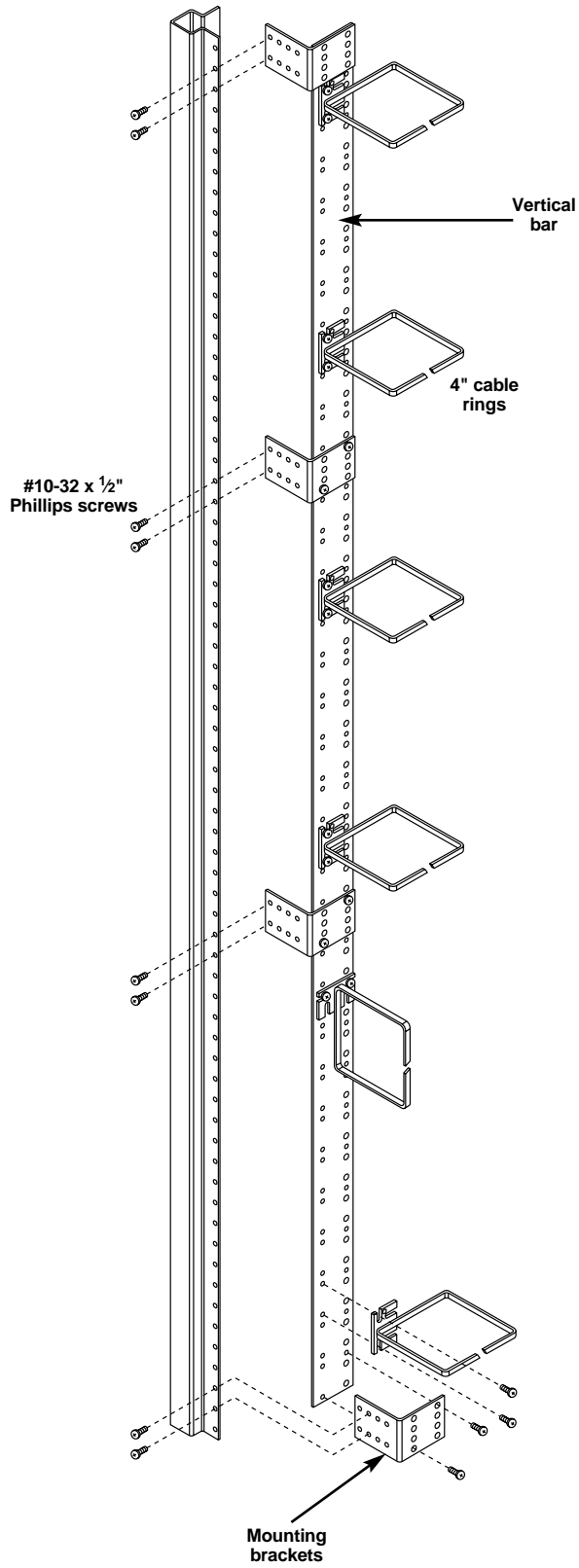

8. Casters and Fan Assemblies

Casters

For mobility, order a set of six casters (RF203). The only color available is black.

Fan Assembly

AVAILABLE MODELS

The Fan Assembly is available in two colors: black (RF207) and beige (RF307).

DESCRIPTION

This panel of three fans with guards exhausts warm air and cools equipment in your cabinet. Each fan moves air at 75 cfm.

INSTALLATION

- 1) Remove the three fan knockouts by pushing down on one side and then twisting back and forth until the tabs break off.
- 2) Hold the fan assembly up to the inside of the top of the cabinet so that the mounting holes in the fans match up with the mounting holes in the top of the rear of the cabinet. Make sure that the fan cord is toward the rear of the cabinet.
- 3) Place three fan guards over the mounting holes in the top of the cabinet.
- 4) Insert twelve #8-32 x $\frac{3}{4}$ " long self-drilling and tapping screws down through the fan guard, through the top of the cabinet and into the fan assembly.
- 5) Three fan guards are also pre-assembled and installed on the bottom of the fan assembly.

ELITE SC AND ACCESSORIES

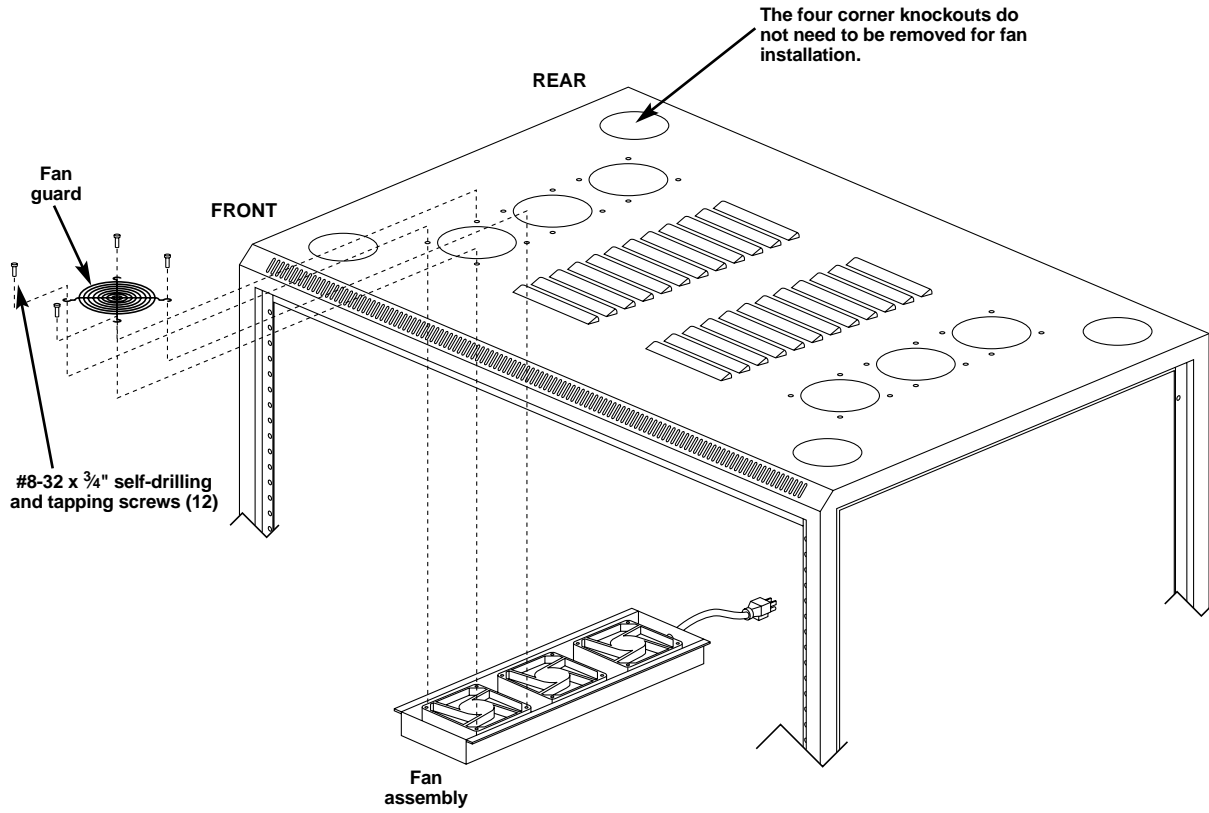

NOTES

NOTES