



VPN: ISBBRM044

© Copyright 2000. Black Box Corporation. All rights reserved.

1000 Park Drive • Lawrence, PA 15055-1018 • 724-746-5500 • Fax 724-746-0746



JULY 2000

RM044	RM430A
RM330A-R3	RM431
RM331	RM432
RM332A	RM630A
RM349A	RM631A
RM378	

Aluminum Distribution Racks

Aluminum Distribution Rack Raceways

Center Weight Shelves

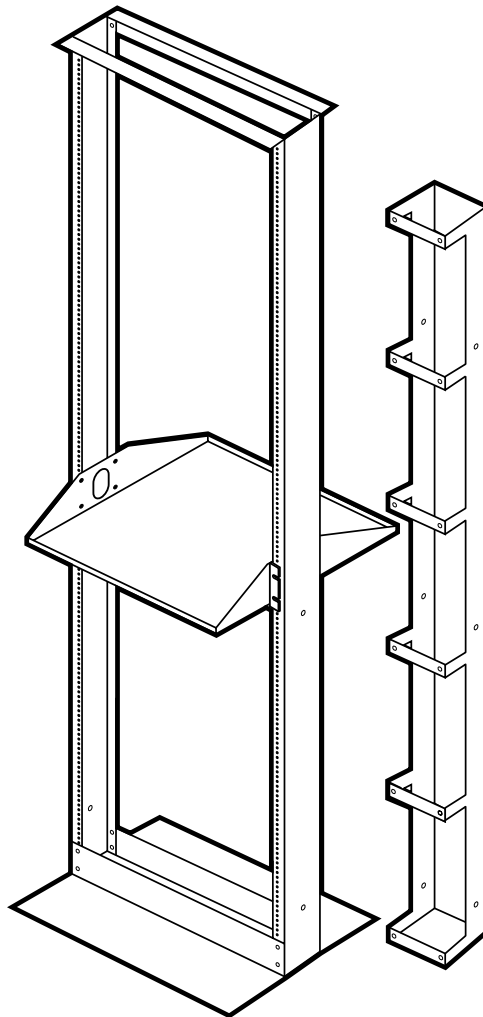

**CUSTOMER
SUPPORT
INFORMATION**

Order **toll-free** in the U.S.: Call **877-877-BBOX** (outside U.S. call **724-746-5500**)
FREE technical support 24 hours a day, 7 days a week: Call **724-746-5500** or fax **724-746-0746**
Mailing address: **Black Box Corporation**, 1000 Park Drive, Lawrence, PA 15055-1018
Web site: www.blackbox.com • E-mail: info@blackbox.com

Contents

- 1. Aluminum Distribution Racks 2
 - 1.1 Available Models..... 2
 - 1.2 What’s Included 2
 - 1.3 What You’ll Need to Supply..... 2
 - 1.4 Installation Instructions..... 2

- 2. Aluminum Distribution Rack Raceways..... 6
 - 2.1 Available Models..... 6
 - 2.2 What’s Included 6
 - 2.3 What You’ll Need to Supply..... 6
 - 2.4 Installation Instructions..... 6

- 3. Center Weight Shelves..... 8
 - 3.1 Available Models..... 8
 - 3.2 What’s Included 8
 - 3.3 What You’ll Need to Supply..... 8
 - 3.4 Installation Instructions..... 8

TRADEMARKS USED IN THIS MANUAL

Any trademarks mentioned in this manual are acknowledged to be the property of the trademark owners.

1. Aluminum Distribution Racks

1.1 Available Models

The following models are available:

- Black Aluminum Distribution Rack, 47" (24U), 10/32 tapped holes (part number RM332A)
- Mill Aluminum Distribution Rack, 66" (35U), 10/32 tapped holes (part number RM349A)
- Black Aluminum Distribution Rack, 84" (45U), 10/32 tapped holes (part number RM330A-R3)
- Black Aluminum Distribution Rack, 84" (45U), 12/24 tapped holes (part number RM630A)
- Mill Aluminum Distribution Rack, 84" (45U), 10/32 tapped holes (part number RM430A)
- Mill Aluminum Distribution Rack, 84" (45U), 12/24 tapped holes (part number RM631A)

1.2 What's Included

Make sure you have the following parts before assembling the Rack.

- (2) vertical upright channels
- (2) base angles
- (2) top angles
- (12) ½"-13 x 1 hex-head bolts
- (12) ½" lockwashers

1.3 What You'll Need to Supply

- ¾" socket or wrench

1.4 Installation Instructions

STEP 1: Attach the top angle to the vertical upright channels. (See **Figure 1-1**.)

- A. Lay the vertical upright channels on edge so the tapped holes face you and the floor. Be sure that open sides of the upright channels face each other.
- B. Align the holes in the top angle with the corresponding holes in the vertical uprights. The formed leg of the top angle should be facing you.
- C. Install the two hex-head bolts and lockwashers. Finger-tighten only.

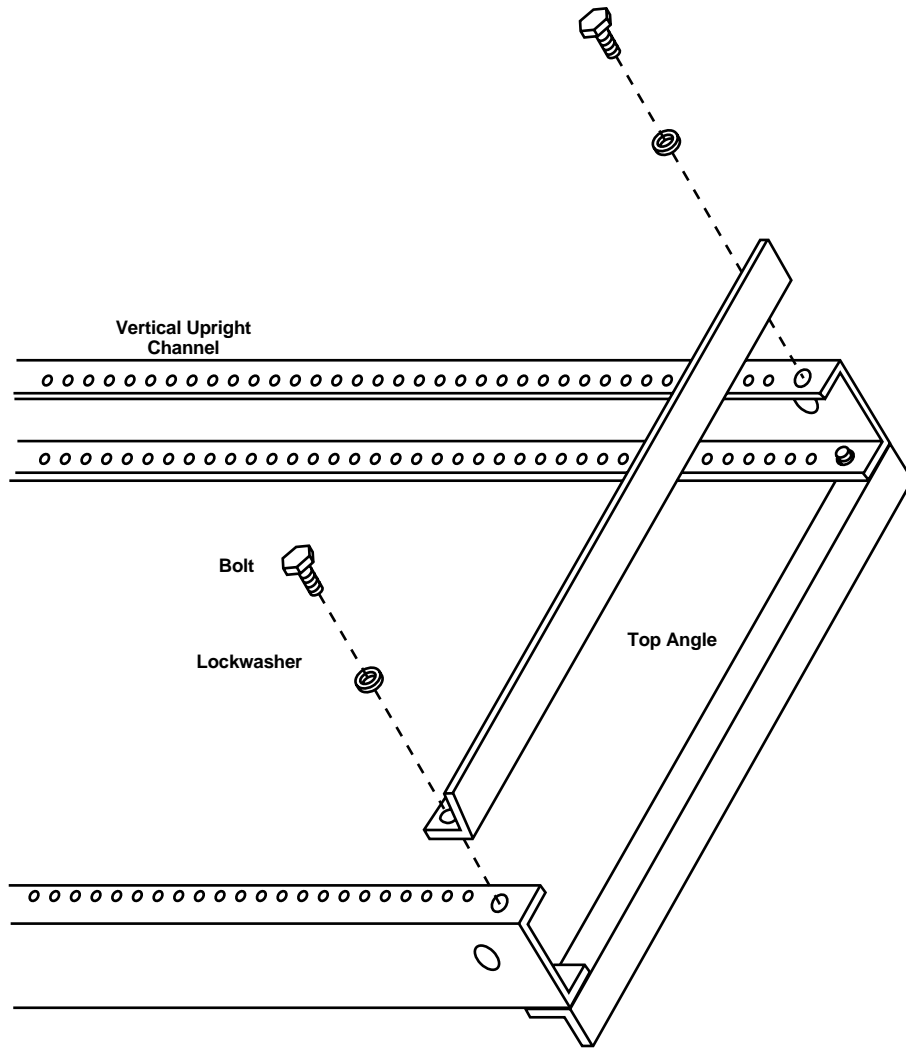

Figure 1-1. Step 1: Attaching the Top Angle to the Vertical Channel Uprights.

ALUMINUM DISTRIBUTION RACKS, RACEWAYS, AND ACCESSORIES

STEP 2: Attach the base angles to the vertical upright channels. (See **Figure 1-2.**)

- A. Leaving the vertical upright channels on edge, align the holes in the base with the corresponding holes in each upright channel. The long leg of the base should be facing you.
- B. Install four hex-head bolts and lockwashers. Finger-tighten only.
- C. Turn the vertical upright assembly over (rotate 180°) and repeat steps A and B. Finger-tighten only.

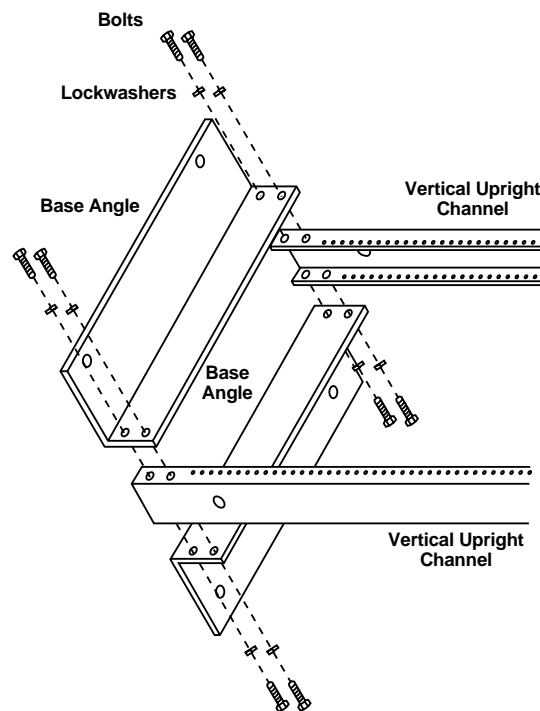

Figure 1-2. Step 2: Attaching the Base Angles to the Vertical Upright Channels.

STEP 3: Final tightening. (See **Figure 1-3**.)

- A. Stand the frame upright.
- B. Square the unit using a level or a carpenter's square.
- C. Tighten all bolts using a socket wrench or a wrench.

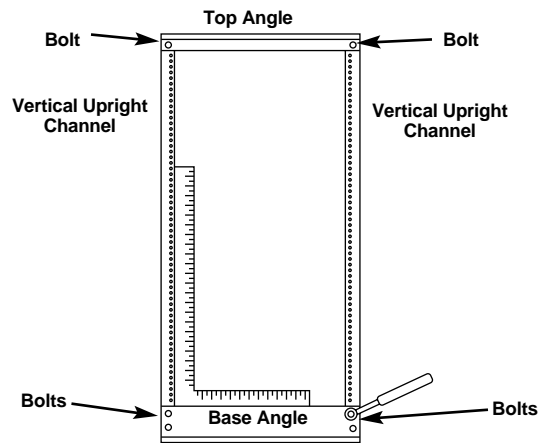

Figure 1-3. Step 3: Final Tightening.

STEP 4: Secure the frame to the floor.

All frames should be bolted to the floor or to an equally stabilizing and secure surface. Determine the desired location and secure the frame.

STEP 5: Equipment installation.

Your rack is now ready for installing equipment and panels.

2. Aluminum Distribution Rack Raceways

2.1 Available Models

The following models are available:

- Mill Aluminum Distribution Raceway for RM349A (part number RM378)
- Black Aluminum Distribution Raceway for RM330A-R3 and RM630A (part number RM044)
- Mill Aluminum Distribution Raceway for RM430A and RM631A (part number RM432)

2.2 What's Included

Make sure you have the following parts before installing the Aluminum Distribution Rack Raceway.

- (1) Aluminum Distribution Rack Raceway
- (6) ½-13" lockwashers
- (6) ½-13 x 1" hex-head bolts
- (6) ½" hexnuts

2.3 What You'll Need to Supply

- ¾" socket or wrench

2.4 Installation Instructions

NOTE

This Rack Raceway attaches to each networking frame with 2 bolts, lockwashers, and hexnuts. After you've properly installed the Rack, you'll have 2 extra bolts, lockwashers, and hexnuts left over.

- A. Align the holes in the Aluminum Distribution Rack Raceway with the holes in the networking frames and attach them with the hex-head bolts, lockwashers, and hexnuts and tighten. (See **Figure 2-1** on the next page.)
- B. Pull the knob on the cable gates to remove them from the Rack. Re-attach by pushing the knob in until it locks.

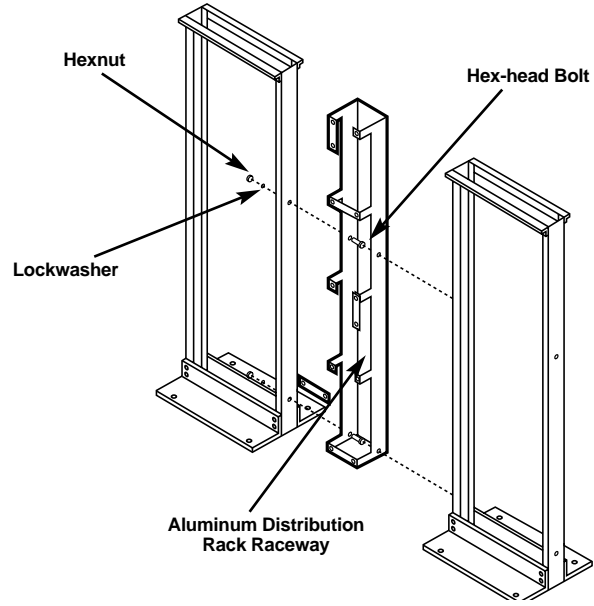

Figure 2-1. Aluminum Distribution Rack Raceway.

3. Center Weight Shelves

3.1 Available Models

The following models are available:

- Black Center Weight Shelf (part number RM331)
- Mill Center Weight Shelf (part number RM431)

3.2 What's Included

Make sure you have the following parts before installing the Center Weight Shelf.

- (1) Center Weight Shelf
- (8) cup-head screws #10-32 x $\frac{5}{8}$ " and (8) cup-head screws #12-24 x $\frac{5}{8}$ "
- (4) #10-32 x $\frac{3}{8}$ " screws
- (2) shelf brackets
- (4) #10-32 hex nuts

3.3 What You'll Need to Supply

- Phillips screwdriver
- Adjustable wrench

3.4 Installation Instructions

NOTE

You may install the shelf with the flanges up or down.

- A. Carefully position the shelf so that the mounting slots in the shelf brackets align with the holes in the uprights.
- B. Attach the shelf to the uprights by inserting two cup-head screws through each shelf bracket into the holes in the uprights.
- C. Attach the shelf brackets to the side of the shelf using two 10-32 x $\frac{3}{8}$ " screws and two hex nuts. Repeat for the second shelf bracket. Do not tighten at this time.
- D. Install the two cup-head screws through each shelf bracket into the holes in the rear of the upright.
- E. Tighten all cup-head screws and hex nuts attaching brackets to the shelf.

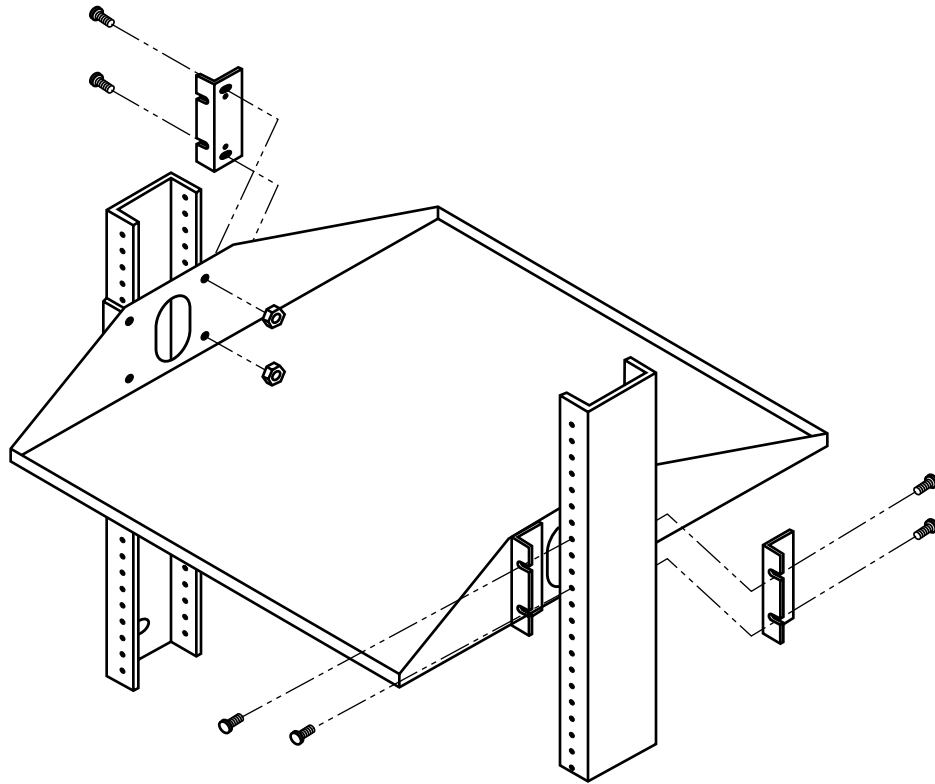

Figure 3-1. Assembling the Center Weight Shelf.